



MUNICIPAL DISTRICT OF GREENVIEW No. 16

COMMITTEE OF THE WHOLE MEETING AGENDA

Monday, July 15, 2019

9:00 AM

Eagle's Nest Hall
Grande Cache, AB

#1	CALL TO ORDER		
#2	ADOPTION OF AGENDA		
#3	MINUTES	3.1 Committee of the Whole Meeting minutes held June 17, 2019 – to be adopted.	2
		3.2 Business Arising from the Minutes	
#4	DELEGATION	9:15 a.m. 4.1 Little Smoky Caribou Rearing Facility	6
		9:30 a.m. 4.2 Canadian Fibre Optic Presentation	16
		10:00 a.m. 4.3 Grande Cache Wayfinding Program	33
		10:15 a.m. 4.4 Powers & Associates Appraisal Services Inc. – 2019 Assessment Presentation	68
#5	NEW BUSINESS	5.1 Northwest Regional Fire Training Centre	84
		5.2 CAO Action List	88
#6	CLOSED SESSION		
#7	ADJOURNMENT		

Minutes of a
COMMITTEE OF THE WHOLE MEETING
MUNICIPAL DISTRICT OF GREENVIEW NO. 16
Grovedale Public Services Building
Grovedale Alberta, on Monday, June 17, 2019

1:
CALL TO ORDER

Chair Bill Smith called the meeting to order at 10:08 a.m.

PRESENT

Ward 8	Chair Bill Smith
Ward 2	Councillor Dale Gervais(2:59 p.m.)
Ward 3	Councillor Les Urness
Ward 4	Councillor Shawn Acton
Ward 6	Councillor Tom Burton (Teleconference)
Ward 7	Councillor Roxie Rutt
Ward 8	Councillor Bill Smith
Division 9	Councillor Duane Didow
Division 9	Councillor Tyler Olsen

ATTENDING

Chief Administrative Officer	Denise Thompson
General Manager, Community Services	Stacey Wabick
General Manager, Corporate Services	Rosemary Offrey
General Manager, Infrastructure & Planning	Roger Autio
Recording Secretary	Teresa Marin.

ABSENT

Ward 1	Deputy Reeve Winston Delorme
--------	------------------------------

#2:
AGENDA

MOTION: 19.06.45. Moved by: COUNCILLOR TOM BURTON
That the Monday, June 17, 2019 Committee of the Whole agenda be adopted as amended:

- Agenda Item 4.1 move to after agenda item 4.4
- Agenda Item addition 7.3 Closed Session – Disclosure Harmful to Economic and Other Interests of a Public Body (FOIPP; Section 25)

CARRIED

#3.1
COMMITTEE OF THE
WHOLE MINUTES

MOTION: 19.06.46. Moved by: COUNCILLOR SHAWN ACTON
That the Minutes of the Committee of the Whole meeting held on Tuesday, May 21, 2019 be adopted as amended:

- Chief Administrative Officer remove Interim prefix
- General Manager, Infrastructure & Planning remove Acting prefix

CARRIED

#3.2
BUSINESS ARISING

3.2 BUSINESS ARISING FROM MINUTES:

Councillor Tom Burton vacated the meeting at 10:20 a.m.

**#4
DELEGATIONS**

4.0 DELEGATIONS

4.3 NITEHAWK ROAD MAINTENANCE PRESENTATION

**NITEHAWK ROAD
MAINTENANCE =
ADMINISTRATION
PRESENTATION**

MOTION: 19.06.47. Moved by: REEVE DALE SMITH
That Committee of the Whole accept the Nitehawk Road Maintenance Report for information, as presented.

CARRIED

**NITEHAWK OPTION
REPORT**

MOTION: 19.06.48. Moved by: COUNCILLOR ROXIE RUTT
That Committee of the Whole direct Administration to present a report at the next Council Meeting with three options for responding to the Nitehawk Road Maintenance request.

CARRIED

4.4 MULTIPLEX ROAD ACCESS OPTIONS

**MULTIPLEX ROAD
ACCESS OPTIONS**

MOTION: 19.06.49. Moved by: COUNCILLOR SHAWN ACTON
That Council accept the presentation for the Multiplex options for information, as presented.

CARRIED

Chair Bill Smith recessed the meeting at 11:20 a.m.

Chair Bill Smith reconvened the meeting at 11:30 a.m.

4.2 ASSESSMENT SERVICES BRANCH – 2019 LINEAR ASSESSMENT PRESENTATION

**ASSESSMENT SERVICES
BRANCH – 2019 LINEAR
ASSESSMENT
PRESENTATION**

MOTION: 19.06.50. Moved by: COUNCILLOR TYLER OLSEN
That Committee of the Whole accept the Assessment Services Branch, Linear Property Assessment Unit's presentation for information, as presented.

CARRIED

Chair Bill Smith recessed the meeting at 12:12 p.m.

Chair Bill Smith reconvened the meeting at 12:52 p.m.

4.3 NITEHAWK ROAD MAINTENANCE PRESENTATION

**NITEHAWK
REPRESENTATIVES –
ROAD MAINTENANCE
REQUEST
PRESENTATION**

MOTION: 19.06.51. Moved by: REEVE DALE SMITH
That Committee of the Whole accept the Nitehawk Road Maintenance Request Presentation for information, as presented.

CARRIED

4.1 TRI-MUNICIPAL INDUSTRIAL PARTNERSHIP PRESENTATION

TRI-MUNICIPAL
INDUSTRIAL
PARTNERSHIP
PRESENTATION

MOTION: 19.06.52. Moved by: COUNCILLOR SHAWN ACTON
That Committee of the Whole accept the presentation from PTAG regarding
the Tri-Municipal Industrial Partnership for information, as presented.

CARRIED

Chair Bill Smith recessed the meeting at 2:15 p.m.
Chair Bill Smith reconvened the meeting at 2:22 p.m.

#5
OLD BUSINESS

5.0 OLD BUSINESS

There was no Old Business presented.

#6
NEW BUSINESS

6.0 NEW BUSINESS

6.1 ACTION LIST

ACTION LIST

MOTION: 19.06.53. Moved by: COUNCILLOR TYLER OLSEN
That Committee of the Whole accept the Action List for information, as
presented.

CARRIED

#7
CLOSED SESSION

7.0 CLOSED SESSION

CLOSED SESSION

MOTION: 19.06.54. Moved by: REEVE DALE SMITH
That the meeting go to Closed Session, at 2:25 p.m., pursuant to Section 197
of the Municipal Government Act, 2000, Chapter M-26 and amendments
thereto, and Division 2 of Part 1 of the Freedom of Information and Protection
of Privacy Act, Revised Statutes of Alberta 2000, Chapter F-25 and
amendments thereto, to discuss Privileged Information with regards to the
Closed Session.

CARRIED

7.1 DISCLOSURE HARMFUL TO PERSONAL PRIVACY (FOIP; Section 17)

7.2 DISCLOSURE HARMFUL TO ECONOMIC AND OTHER INTERESTS OF A PUBLIC BODY (FOIP; Section 25)

**7.3 DISCLOSURE HARMFUL TO ECONOMIC AND OTHER INTERESTS OF A
PUBLIC BODY**

(FOIP; Section 25)

OPEN SESSION

MOTION: 19.06.55. Moved by: COUNCILLOR SHAWN ACTON
That, in compliance with Section 197(2) of the Municipal Government Act, this
meeting come into Open Session at 3:41 p.m.

CARRIED

Councillor Dale Gervais entered the meeting at 2:59 p.m.

#8
ADJOURNMENT

8.0 ADJOURNMENT

MOTION: 19.06.56. Moved by: COUNCILLOR SHAWN ACTON
That this meeting adjourn at 3:45 p.m.

CARRIED

CHIEF ADMINISTRATIVE OFFICER

CHAIR



REQUEST FOR DECISION

SUBJECT: **Little Smoky Caribou Rearing Facility**
SUBMISSION TO: COMMITTEE OF THE WHOLE
MEETING DATE: January 14, 2019
DEPARTMENT: COMMUNITY SERVICES
STRATEGIC PLAN: Intergovernmental Relations

REVIEWED AND APPROVED FOR SUBMISSION
CAO: DT
GM: SW
MANAGER:
PRESENTER:

RELEVANT LEGISLATION:

Provincial (cite) – N/A

Council Bylaw/Policy (cite) – N/A

RECOMMENDED ACTION:

MOTION: That Committee of the Whole accept the Little Smoky Caribou Rearing Facility presentation from Alberta Environment and Parks for information, as presented.

BACKGROUND/PROPOSAL:

Alberta Environment and Parks (AEP) representatives, Megan Watters and Dave Hervieux will be in attendance to provide Council with information regarding the Little Smoky Caribou Rearing facility.

The intent of the rearing facility is to provide a predator-free environment for increasing the survival of caribou adults and calves. At the time of receiving the presentation request form, May 16, 2019 Alberta Environment and Parks (AEP) was in the design and survey phase of the project. AEP had intended to make the presentation to Council May 21st, however with the election and the change in Alberta Government, the presenters asked to postpone their presentation. The second attempt to schedule the meeting was for June 17th. Council was making a decision at the May 27th Meeting to cancel or affirm the June 17th Committee of the Whole Meeting. With the possibility of the June 17th meeting being cancelled, AEP made other arrangements and were unable to attend.

Council will be provided with the current to-date information on the status of the rearing facility.

BENEFITS OF THE RECOMMENDED ACTION:

1. The benefit of accepting the presentation is to confirm receipt of the Caribou Rearing Facility presentation provided by Alberta Environment and Parks.
-

DISADVANTAGES OF THE RECOMMENDED ACTION:

2. There are no perceived disadvantages to the recommended motion.
-

ALTERNATIVES CONSIDERED: N/A

FINANCIAL IMPLICATION:

There are no financial implications to the recommended motion.

STAFFING IMPLICATION:

There are no staffing implications to the recommended motion.

PUBLIC ENGAGEMENT LEVEL:

Greenview has adopted the IAP2 Framework for public consultation.

INCREASING LEVEL OF PUBLIC IMPACT

Inform

PUBLIC PARTICIPATION GOAL

Inform - To provide the public with balanced and objective information to assist them in understanding the problem, alternatives, opportunities and/or solutions.

PROMISE TO THE PUBLIC

Inform - We will keep you informed.

FOLLOW UP ACTIONS:

There are no follow up actions to the recommended motion.

ATTACHMENT(S):

- PowerPoint Presentation

Little Smoky Rearing Facility

Stakeholder Engagement

Dave Hervieux, Provincial Caribou Management Coordinator

Megan Watters, Wildlife Recovery Biologist

Barry Nobeit, Caribou Biologist

July 15, 2019



What is a Rearing Facility?

- Large area of natural habitat surrounded by a predator-proof fence
- Allows caribou to live year-round in a predator free environment:
 - increase calf and adult caribou survival
 - boost the wild population

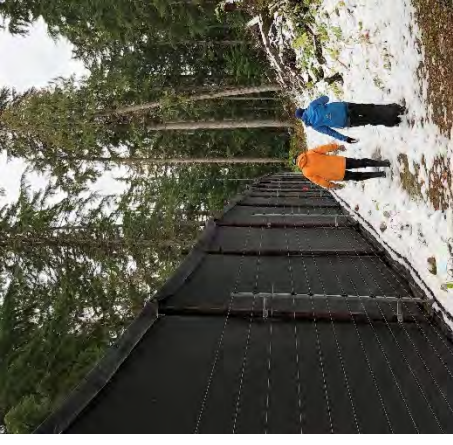

Intent of the Little Smoky Rearing Facility

- Enable the persistence of the Little Smoky caribou herd while habitat restoration, integrated land management planning, and other management actions are used
- Help the GOA meet the federal expectations of maintaining self-sustaining caribou populations (*Species at Risk Act*)
- Serve as a pilot to help us learn about rearing facilities as a recovery tool

Little Smoky Rearing Facility

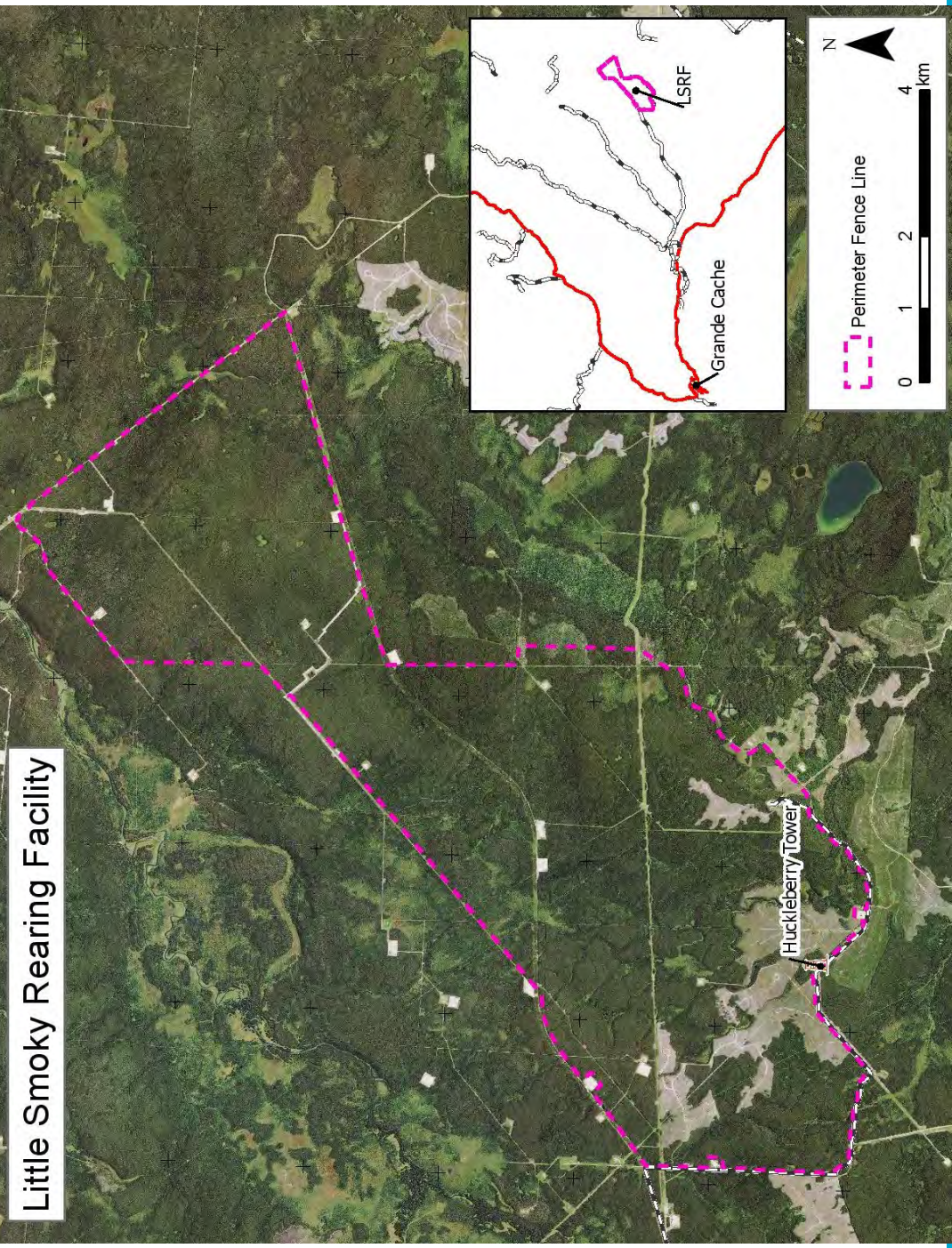

The Big Fence

- 8 ft tall game fence with woven wire and steel posts
- Electric high tensile wires on external outrigger
- Buried or pinned chain-link apron
- Locked gate



Activity Timeline

Phase	Date
Planning	Present to November 2019
Construction	December 2019 – March 2020
Predator Removal and monitoring	April 2020 – January 2021
Caribou capture	February – March 2021
Facility implementation	March 2021 onwards



Planning

- Contract for survey and design component of construction
- Continue development of management plans. For example:
 - Industrial and access management
 - Research and monitoring
 - Animal husbandry and health
- Continued engagement







REQUEST FOR DECISION

SUBJECT: **Canadian Fibre Optics Presentation**
SUBMISSION TO: COMMITTEE OF THE WHOLE
MEETING DATE: July 15, 2019
DEPARTMENT: CAO SERVICES
STRATEGIC PLAN: Level of Service

REVIEWED AND APPROVED FOR SUBMISSION
CAO: DT
GM:

MANAGER:
PRESENTER:

RELEVANT LEGISLATION:

Provincial (cite) – N/A

Council Bylaw/Policy (cite) – N/A

RECOMMENDED ACTION:

MOTION: That Committee of the Whole accept the presentation from Canadian Fibre Optics for information as presented.

BACKGROUND/PROPOSAL:

Update on Canadian Fiber Optics progress of Fiber Optic infrastructure build within the MD of Greenview and roll out of high speed internet services for industrial clients. Information on the importance of fiber based connectivity and opportunities for Canadian Fiber Optics to serve the MD of Greenview.

BENEFITS OF THE RECOMMENDED ACTION:

1. The benefit of accepting the presentation is to confirm receipt of the Council update from Canadian Fibre Optics.
-

DISADVANTAGES OF THE RECOMMENDED ACTION:

1. There are no perceived disadvantages to the recommended motion.
-

ALTERNATIVES CONSIDERED:

N/A

FINANCIAL IMPLICATION:

There are no financial implications to the recommended motion.

STAFFING IMPLICATION:

There are no staffing implications to the recommended motion.

PUBLIC ENGAGEMENT LEVEL:

Greenview has adopted the IAP2 Framework for public consultation.

INCREASING LEVEL OF PUBLIC IMPACT

Inform

PUBLIC PARTICIPATION GOAL

Inform - To provide the public with balanced and objective information to assist them in understanding the problem, alternatives, opportunities and/or solutions.

PROMISE TO THE PUBLIC

Inform - We will keep you informed.

FOLLOW UP ACTIONS:

There are no follow up actions to the recommended motion.

ATTACHMENT(S):

- CFOC Presentation



EXPAND YOUR VISION
GREENVIEW

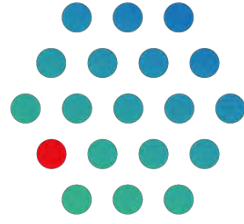

CANADIAN
FIBER OPTICS

Presentation Agenda



Introduction



The Last 12 months



Why Fiber?



Supporting the MD



Next Steps



Who are we?

Local, Invested, Committed

Backed by two local families, Canadian Fiber Optics has \$10 million worth of long term infrastructure between Wembley and Grande Cache.

Our Mission: To provide the foundation of connectivity to forward thinking communities and business, enabling access to new and evolving technologies.

Our Vision: To bring connectivity to all within **our reach...**

Our strategic pillars: Safety, People, Growth and Efficiency

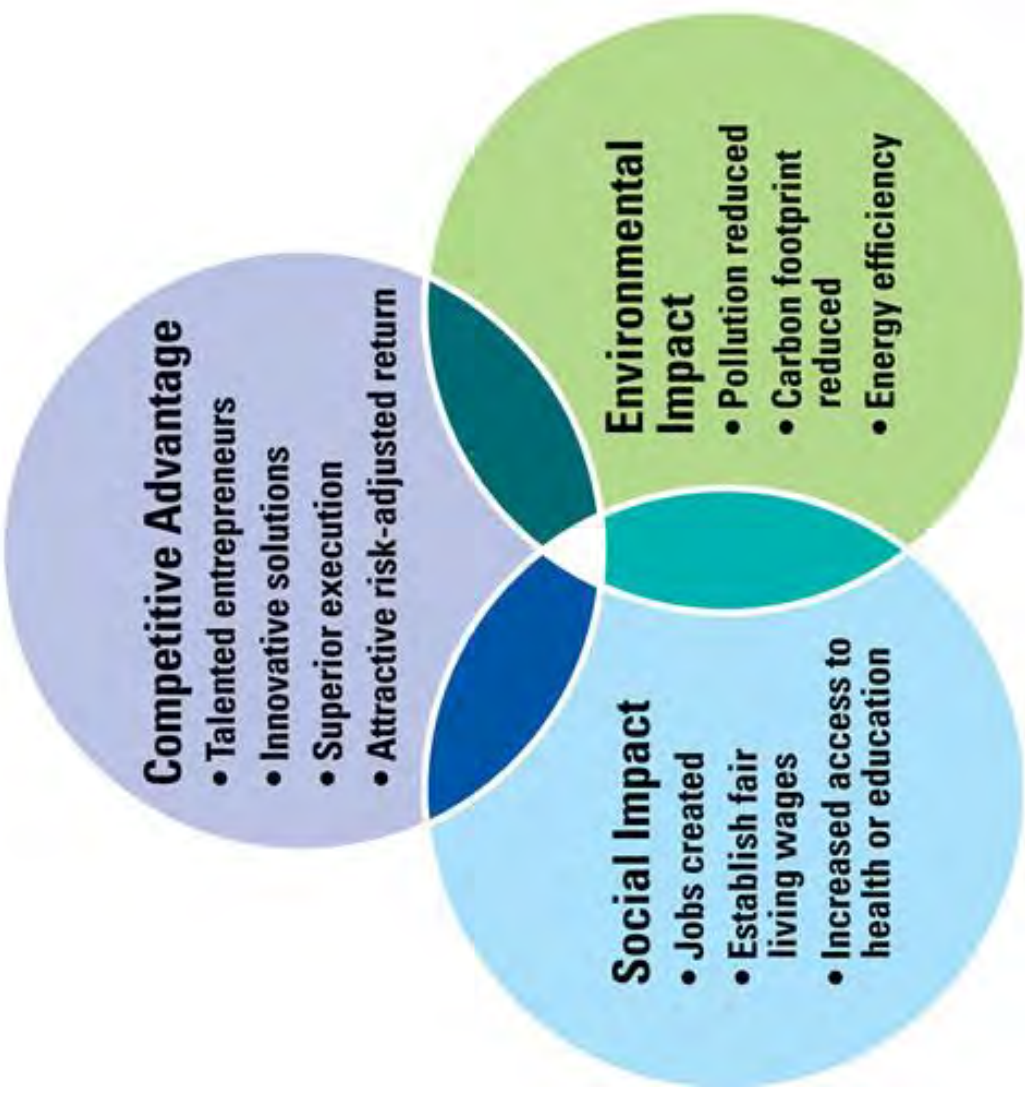

Invest. Consult. Design. Build. Connect. Operate.



Invest in rural and remote areas like the Wembley to Grande Cache route.



Consult to municipalities, Counties and Districts to find the right infrastructure and connectivity solutions for its residents.



Design and Build fiber optic infrastructure with the region and the future in mind.

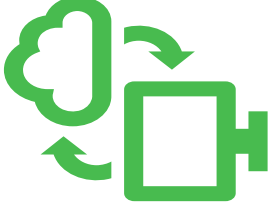

Connect municipalities and counties with high bandwidth fiber optic connections.
Connect remote industrial sites, field office to head office and from head office to wellhead in remote and hard to reach locations.



Operate and maintain fiber optic networks to ensure reliable internet services are delivered to our customers.



The Last 12 months...

Haida Gwaii Project Connect

General Contractor to build
fiber to 620 homes in five
communities and first nations
reserves on the islands of
Haida Gwaii

\$3.5M contract

12 km subsea fiber build



Why Fibre?



Fiber has set the standard as the most reliable form of **connectivity...it is:**



the fastest connection
to the internet;



versatile; and,



scalable.

Existing Rural Customer Experience Expensive. Slow. Unreliable.

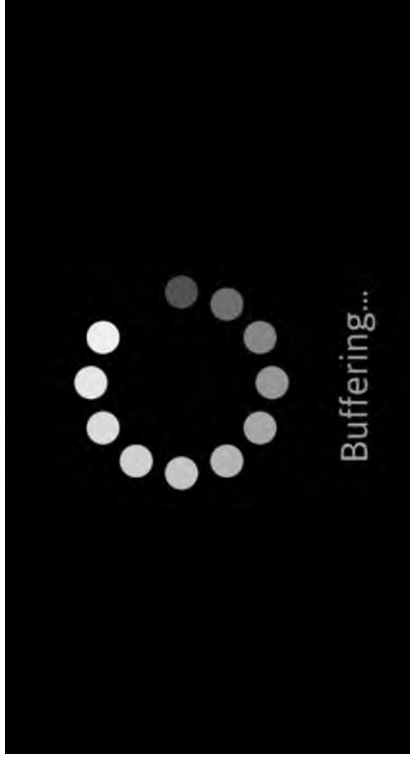

Future Service Levels up to 1000Mbps on fiber.



Residential customer Experience:
Unlimited data.

No more buffering.
Skype, 4K TV, cheap home phone plans
Online gaming , live video
Smart home, security

Industrial customer experience:
Cyber secure connection.

Enable an Enterprise Wide Area Network (WAN)
Super fast access to cloud
Managed service with higher service levels.
Improved security with HD video feeds.
Improved Health, Safety and Environment solutions.

Public Policy Drivers

Municipal Districts, Counties and Municipalities are making fiber infrastructure and broadband services a critical part of their policy mandate. Some of the key drivers include:

- ✓ Lack of Telecom Investment - Perpetual underservice by the incumbent providers have made rural and regional **"have-not"** communities;
- ✓ New Demands for Service - Residential and small business internet demands now exceed existing wireless delivery capacities;
- ✓ Economic Development & Diversity – must attract and keep businesses of all sizes to and in the region; and,
- ✓ Environmental Stewardship – Smart home and Smart City initiatives enable more efficient use of resources together with minimizing environmental impact.



What other Cities, Districts and Counties are doing



Issued a public RFP to build a Rural Fiber Optic Network. CFOC and Valo Networks were awarded the project on June 26, 2019

Utilizing a CARES grant to explore the prospect of creating a Fiber-to-the-Home network for Hythe.



Policy mandate to offer commercial access to city-owned fiber to enable service delivery while minimizing construction disruption and remediation.

Exploring the prospect of acquiring a fiber backbone network to connect the region back to Calgary.



Part of the South Grow Regional Initiative and has created a “One-Dig” policy to include fiber infrastructure.

Together we can support Greenview's Strategic Goals

Strategic Goal: We have well-built and well maintained infrastructure that is sustainable and contributes to quality of life in the region.

Strategic Goal: We will have a diverse economy that decreases our dependency on the petroleum industry.

Strategic Goal: Provide services that exceed the basic needs of our stakeholders and accommodate diverse lifestyles.

Source: Municipal District of Greenview No. 16
Strategic Plan 2017

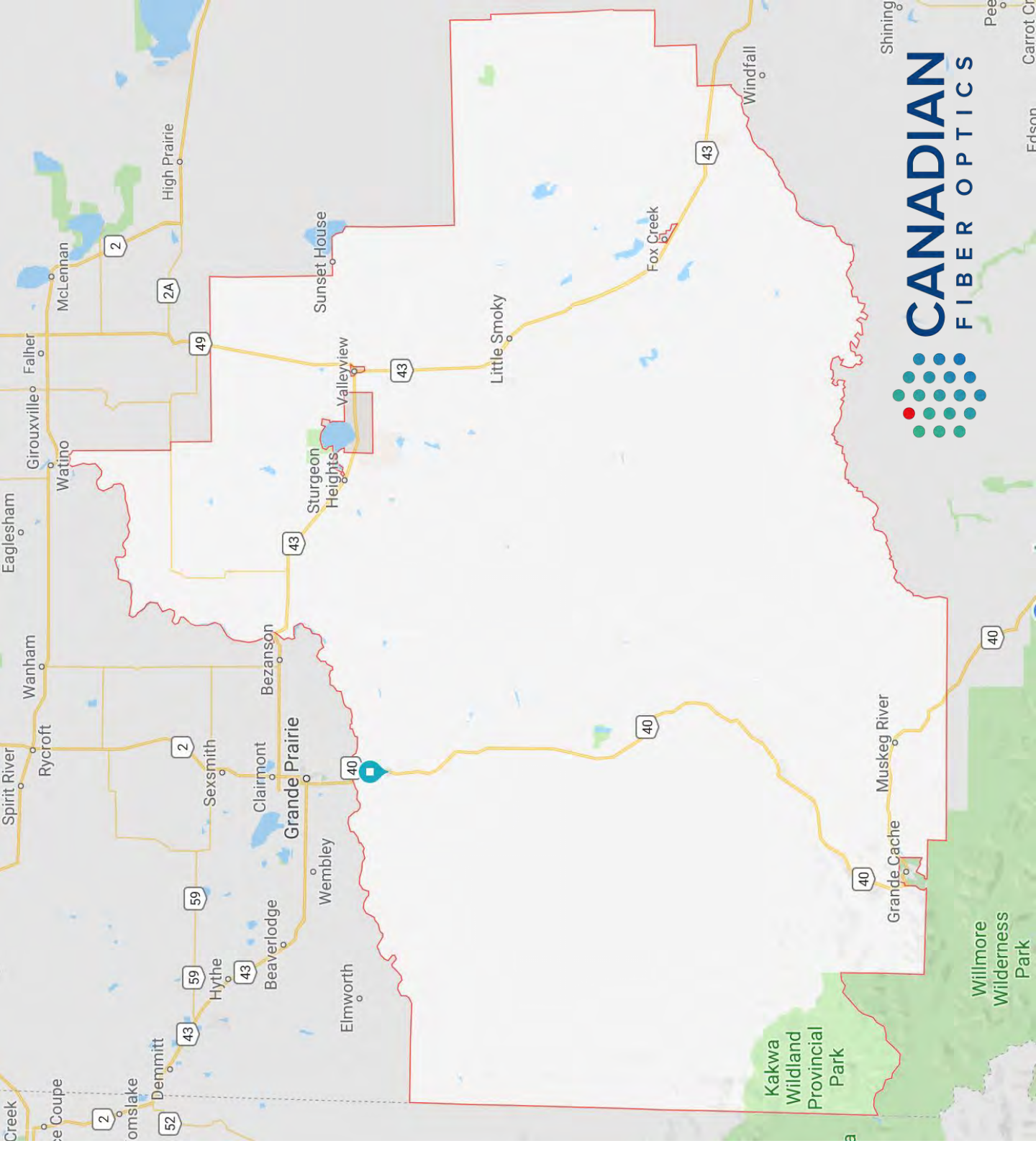

Broadband infrastructure: Opportunities for the MD of Greenview

Drives economic development

Investment retention, attraction & expansion

TeleHealth

Retention of the youth in the region

Distance learning initiatives

Elderly care, Firehall and EMS services connectivity

Environmental monitoring

Safety

Increase use of municipal e-services for ratepayers

How we can serve the residents of the MD of Greenview?

1. Define a pilot project with measurable outcomes for Grovedale, Landry Heights and Grande Cache.
 - o Start by leveraging CFOC infrastructure from Wembley to Grovedale to:
 - Connect the MD office and Fire Station in Grovedale
 - Design and build Fiber-to-the-Home (FTTH) for Grovedale and Landry Heights
2. Fiber to the Home (FTTH) for Grande Cache
 - o Explore approaches and business models to build FTTH.
3. Fiber backbone to connect communities along HWY 43.
 - o Fiber connectivity enables new and next generation services.
 - o Supports businesses in these communities
 - o Fiber to the tower to support service providers
4. Tri-Municipal Industrial Partnership
 - o Leverage existing CFOC backbone down Hwy 40.
 - o Create connectivity plan for the region.

Next Steps?

1. Prioritize target areas
2. Jointly explore engagement approaches, funding opportunities and business models.
3. Scope a pilot project





REQUEST FOR DECISION

SUBJECT: **Grande Cache Wayfinding Program**
SUBMISSION TO: COMMITTEE OF THE WHOLE
MEETING DATE: July 15, 2019
DEPARTMENT: CAO SERVICES
STRATEGIC PLAN: Infrastructure

REVIEWED AND APPROVED FOR SUBMISSION
CAO: DT
GM:
MANAGER:
PRESENTER:

RELEVANT LEGISLATION:

Provincial (cite) – N/A

Council Bylaw/Policy (cite) – N/A

RECOMMENDED ACTION:

MOTION: That Committee of the Whole accept the Grande Cache Wayfinding Program for information as presented.

BACKGROUND/PROPOSAL:

The Grande Cache Wayfinding program was an approved Coal Community Transition Fund project listed in the Alberta Economic Development and Trade Grant Agreement that Grande Cache received in 2018. This project was allocated \$40,000 for the consultant and designs of improved Wayfinding in Grande Cache. The project objectives were to hire a consultant to conduct a comprehensive review of the communities existing signage to produce a program to improve wayfinding. An RFP was advertised in March 2019 and the design and recommendations are attached, completed by EDS Inc.

The Grande Cache Wayfinding System Project purpose is to create a clear, modern, mythological sequence of directional and identification elements (wayfinding) for visitors and residents to connect visitors and locals to our natural surroundings, to outline the relevant locations and destinations, and to communicate movement throughout the community to get people to the places they want to get as easy as possible.

Through visually intuitive designs and consistent messaging, the wayfinding program will ensure guidance from Highway 40 into downtown and to Grande Cache’s key destinations, attractions, facilities, trails, recreation and tourism opportunities.

The wayfinding program seeks to outline the relevant locations and destinations to the following, but not limited to - facilities (such as the Grande Cache Municipal Campground from Highway 40 ,Ball Diamonds from Highway 40, Grande Cache Recreation Centre (that includes a state-of-the-art Aquatic Centre, Curling Rink, Arena, Fitness Centre, Spray Park) Grande Cache Labyrinth, Firemen’s Pit, Parks, Grande Cache Golf & Country Club), things to see & do (such as trailhead signage in and around the community for Sulphur Rim and Griffith Trail trailheads for hiking and biking and signage along the trails), downtown and businesses signs from highway. Many of these signs are outdated and worn out. Many of the facility signs have old Town logos on

them which also include the words “Town of Grande Cache” on them. Maps on the trailhead signs are worn out and outdated as many new trails have been developed.

At present, there are a number of groups within the community (The Canadian Death Race, Hiking Committee, Biking Committee, Wilmore Wilderness Foundation and Grande Cache Chamber of Commerce) that are initiating wayfinding for their respective organizations immediately and this has been an opportunity for all groups to work together to create a comprehensive, inclusive, and coordinated wayfinding system in and around the community.

The goal is to make the community easier to navigate and enhance visitor experience as it increases their comfort, builds their confidence and encourages them to discover our unique and attractions. Wayfinding markers along the trails will help visitors and local residents find their way along the trails.

The creative concept of the signage reflects an essence that evokes the following key words: welcoming, clear, easy to follow, modern, innovative, use natural products and promote healthy, active lifestyle in a mountain surrounding.

The scope of the project included:

- 1) EDS Group retained by the MD of Greenview in response to a public Request for Proposals for a Wayfinding Strategy
- 2) Met with stakeholders on three occasions (April 15, May 9, May 23) to educate, learn, share, update on this project
- 3) Developed a family of signage, refined the proposed designs and locations
- 4) Detailed design of various signs, specifying materials and installation
- 5) Developed a cost estimate for near term signage program

This project will enhance the aesthetics of Grande Cache by preventing sign proliferation and encourage signs that complement, rather than detract from the streetscape. The community will be easier to navigate (we have many complaints that people cannot find the Campground, and that our trails are not marked) which will enhance visitor experiences (as it increases their comfort, builds their confidence and encourages them to discover our unique and attractions). It is an opportunity to update our signage from the Town of Grande Cache wording, old ram logo and past Town logo. As many groups, such as the Death Race, the biking club and the trails group are already initiating these types of signages along trails, it provides the opportunity that the signage be consistent, similar in appearance and with purpose to create a comprehensive, inclusive, and coordinated wayfinding system in and around the community.

BENEFITS OF THE RECOMMENDED ACTION:

1. The benefit of Committee of the Whole accepting the presentation is to confirm receipt on the update by EDS Inc.

DISADVANTAGES OF THE RECOMMENDED ACTION:

1. There are no perceived disadvantages to the recommended motion.

ALTERNATIVES CONSIDERED:

N/A

FINANCIAL IMPLICATION:

There are no financial implications.

STAFFING IMPLICATION:

There are no staffing implications to the recommended motion.

PUBLIC ENGAGEMENT LEVEL:

INCREASING LEVEL OF PUBLIC IMPACT

Inform

PUBLIC PARTICIPATION GOAL

Inform - To provide the public with balanced and objective information to assist them in understanding the problem, alternatives, opportunities and/or solutions.

PROMISE TO THE PUBLIC

Inform - We will keep you informed.

FOLLOW UP ACTIONS:

There is no follow up action to the recommended motion.

ATTACHMENT(S):

- Grande Cache Wayfinding Program PowerPoint Presentation

Grande Cache Wayfinding Program

July 2019

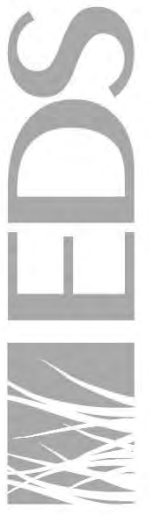

Types of Wayfinding Devices

1. **Directional Signs** – where information is displayed to find destinations, located at several strategic points
2. **Identification Signs** – where information about individual locations is displayed, such as buildings, locations and public amenities
3. **Warning Signs** – to indicate safety procedures such as emergency exit routes, non-smoking areas, park rules or other regulations



Principles of Wayfinding

1. Create a unified palate of colours, shapes and materials.
2. Don't provide too many choices on each sign
3. Provide signs at decision points to signal options
4. Divide different spaces using differing colours
5. Use images where possible, avoiding text. Make icons widely understood



Why a Wayfinding Program for Grande Cache?

- 1) Clearly identify location of various local amenities
- 2) Enhance safety of residents and tourists
- 3) Create a more attractive public realm
- 4) Elevate the community's profile for tourism, and promote economic development
- 5) Coordinate efforts of various local groups with a unified program

Project Scope

- 1) Assess current signage, explore opportunities to re-use existing components where possible
- 2) Meet with local stakeholders to coordinate individual efforts and to meet their needs for signage
- 3) Develop a family of signage for various applications
- 4) Estimate the number of signs required in the near term to properly address wayfinding needs for parks, open space, streetscapes and trails
- 5) Create a community map and a trails map for distribution and promotion of local assets

 **Welcome To**
Grande Cache

GRANDE CACHE
WE ARE A CRIME WATCH COMMUNITY
RCMP COPS
CITIZENS ON PATROL
www.grandecache.ca









Grande Cache ... A Natural High



Griffith Trail
Named after Betty Griffith, an active community volunteer in the 1970s, the Griffith Trail is an intermediate hike that is easily accessed by using Highway 40 North. The trail begins at the north end of the town of Grande Cache and follows the edge of the town. Enjoyed by hikers of all ages, the trail provides a great opportunity to see some of the area's natural beauty. The trail is approximately 1.5 kilometers long and is suitable for hikers of all ages. The trail is a great place to see many exciting species of wildlife, so keep your camera close at hand!

- LEGEND**
- GRIFFITH TRAIL
 - SULPHUR RIM TRAIL
 - GRAND CACHE TRAILS
 - TRAIL HEAD
 - REST AREA
 - LOOK OUT POINT
 - TRAILHEAD



Grande Cache ... A Natural High



Griffith Trail
Named after Betty Griffith, an active community volunteer in the 1970s, the Griffith Trail is an intermediate hike that is easily accessed by using Highway 40 North. The trail begins at the north end of the town of Grande Cache and follows the edge of the town. Enjoyed by hikers of all ages, the trail provides a great opportunity to see some of the area's natural beauty. The trail is approximately 1.5 kilometers long and is suitable for hikers of all ages. The trail is a great place to see many exciting species of wildlife, so keep your camera close at hand!



Be BearSmart
You're in Grizzly country

Carry bear spray. Have bear spray in and ready to use in case of a bear encounter.

Do not feed bears. Do not feed bears. Do not feed bears.

Pick up all garbage in designated bear-proof containers.

Be BearSmart. You're in Grizzly country.



- RETAIL SERVICES
- RV PARKING
- PROVINCIAL BUILDING
- GRANDE CACHE INSTITUTION

GRANDE CACHE
← TOWN CENTRE





WAYFINDING SIGNAGE

Being consistent with an indigenous mountain theme, materials such as stone and wood will be used to create clear and informative wayfinding signage throughout the community.

Existing silhouette

Background fabric accentuates uplighting and extends theming to all aspects of signage.

LIGHTING

Highway lighting showcases 'Grande Promenade'. Signage on Poles will be accentuated with multi coloured backgrounds that are uplit at night to create silhouettes and reflections.



ENTRY FEATURE

Materials such as natural stone and brushed metal are used to create an entry feature which welcomes you to the community. Resilient to vandalism and able to withstand the elements prevalent in the area, the materials used are consistent with the proposed mountain theme.

BENCHES

Common throughout the community, benches can be used for commemorative purposes, to display the town logo and create a place to sit and enjoy the views of the community.

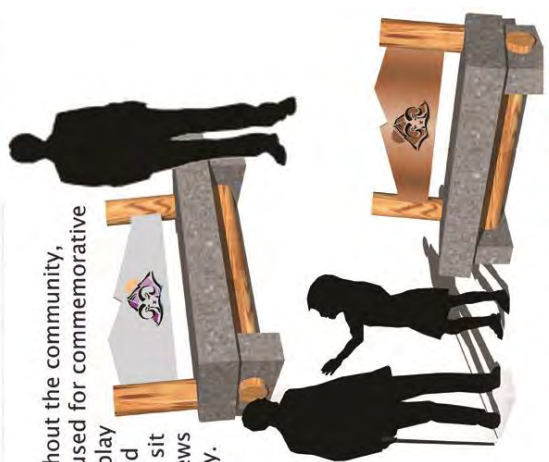

theme and identity

GRANDE CACHE BEAUTIFICATION

TRAILS WAYFINDING SIGNAGE

GRANDE CACHE



directional signage



trail head signage



small scale wayfinding signage

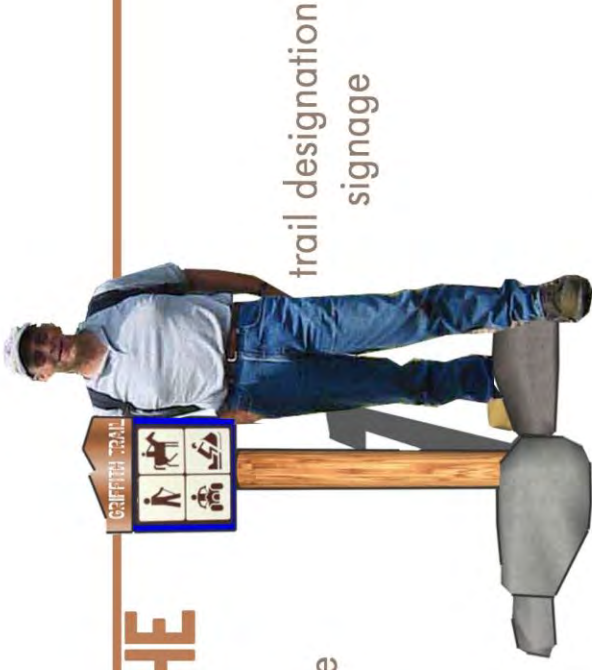

trail designation signage

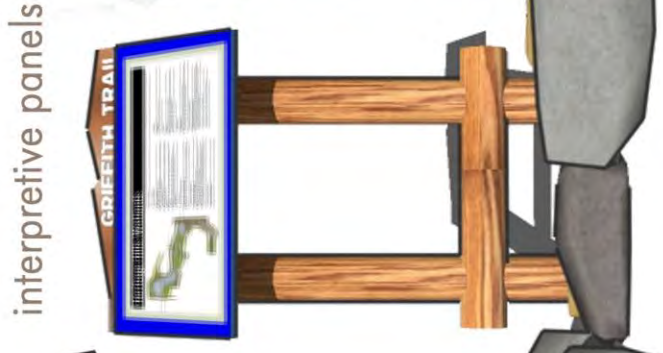

interpretive panels





HOSPITAL



TOWN CENTRE



CAMPGROUND



REC CENTRE



PROVINCIAL BUILDING



HIKING TRAILS







Hoppe Avenue

107 Street





Study Process

- 1) EDS Group retained by the MD of Greenview in response to a public Request for Proposals for a Wayfinding Strategy
- 2) Met with stakeholders on three occasions (April 15, May 9, May 23) to educate, learn, share, update on this project
- 3) Developed a family of signage, refined the proposed designs and locations
- 4) Detailed design of various signs, specifying materials and installation
- 5) Developed a cost estimate for near term signage program

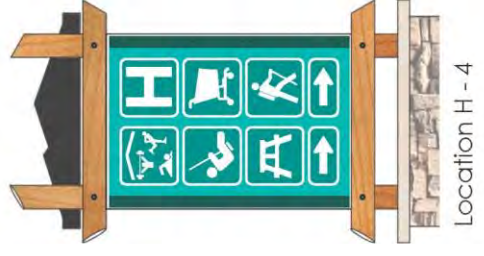
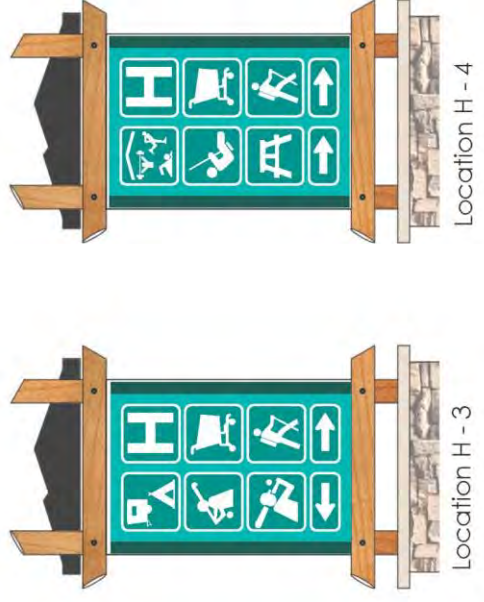
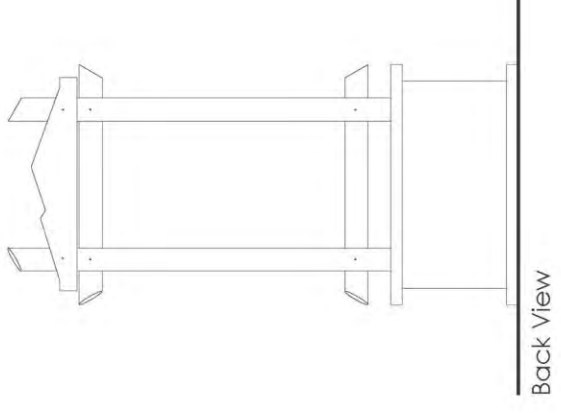
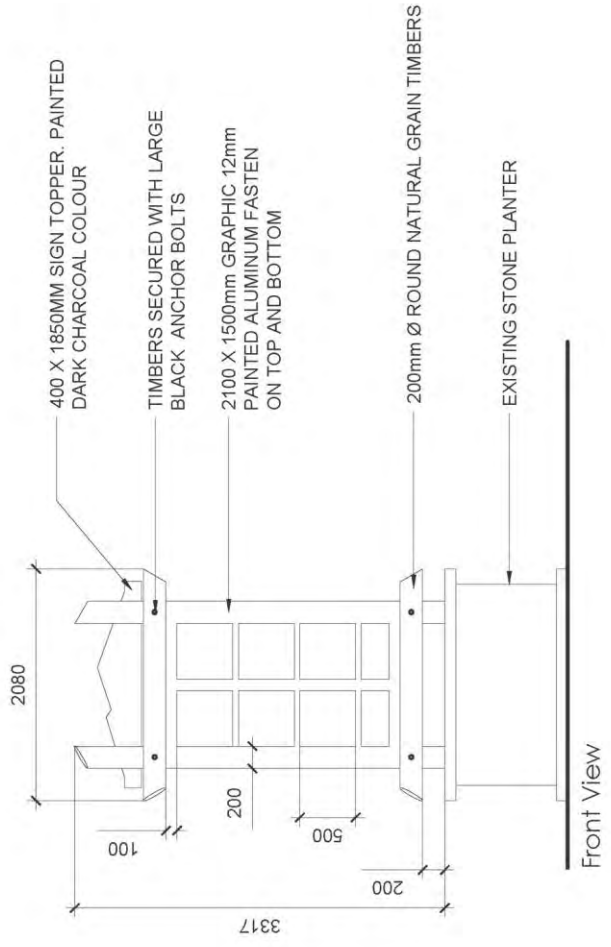
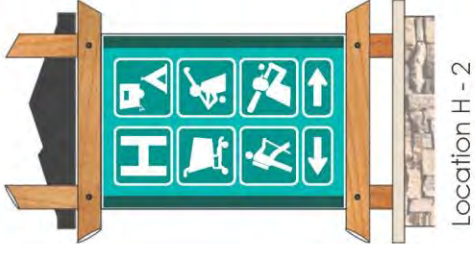
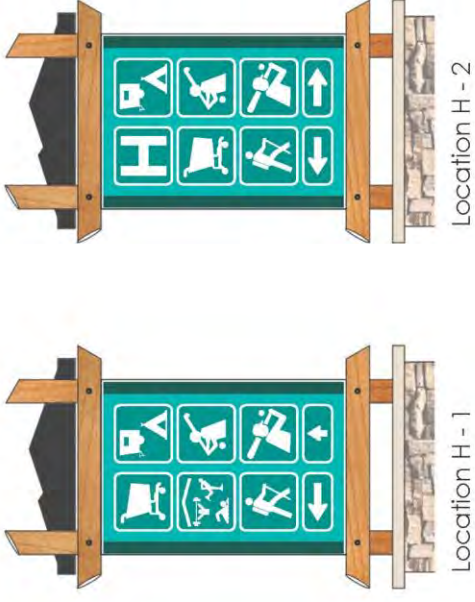
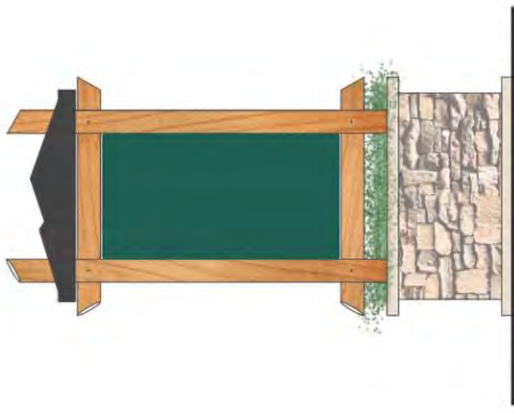
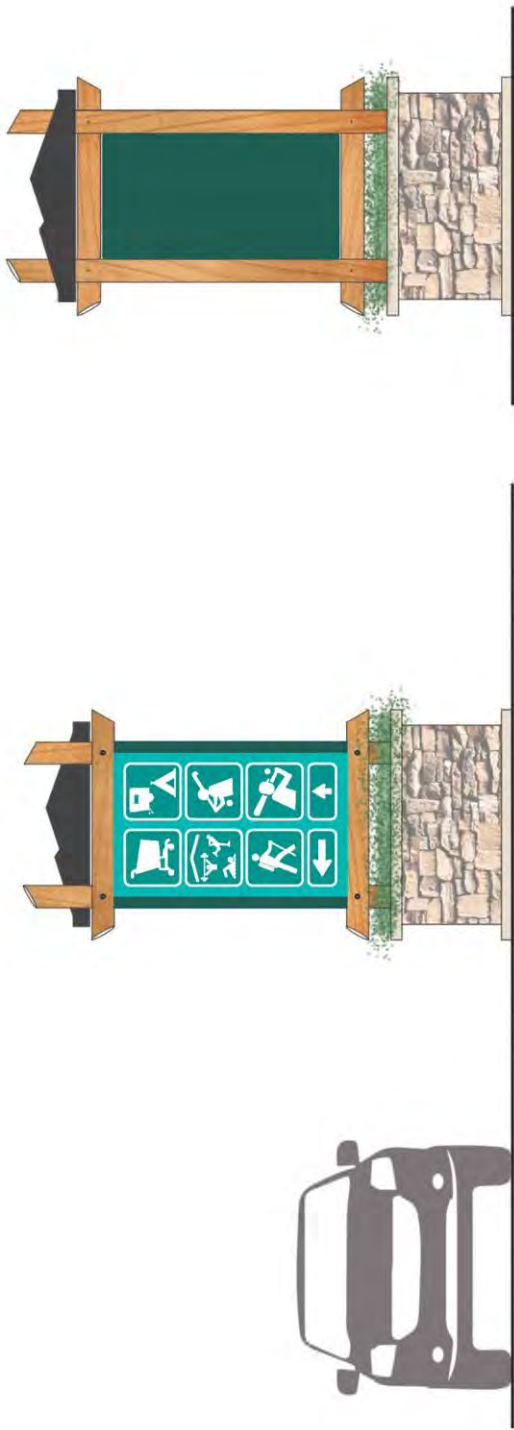

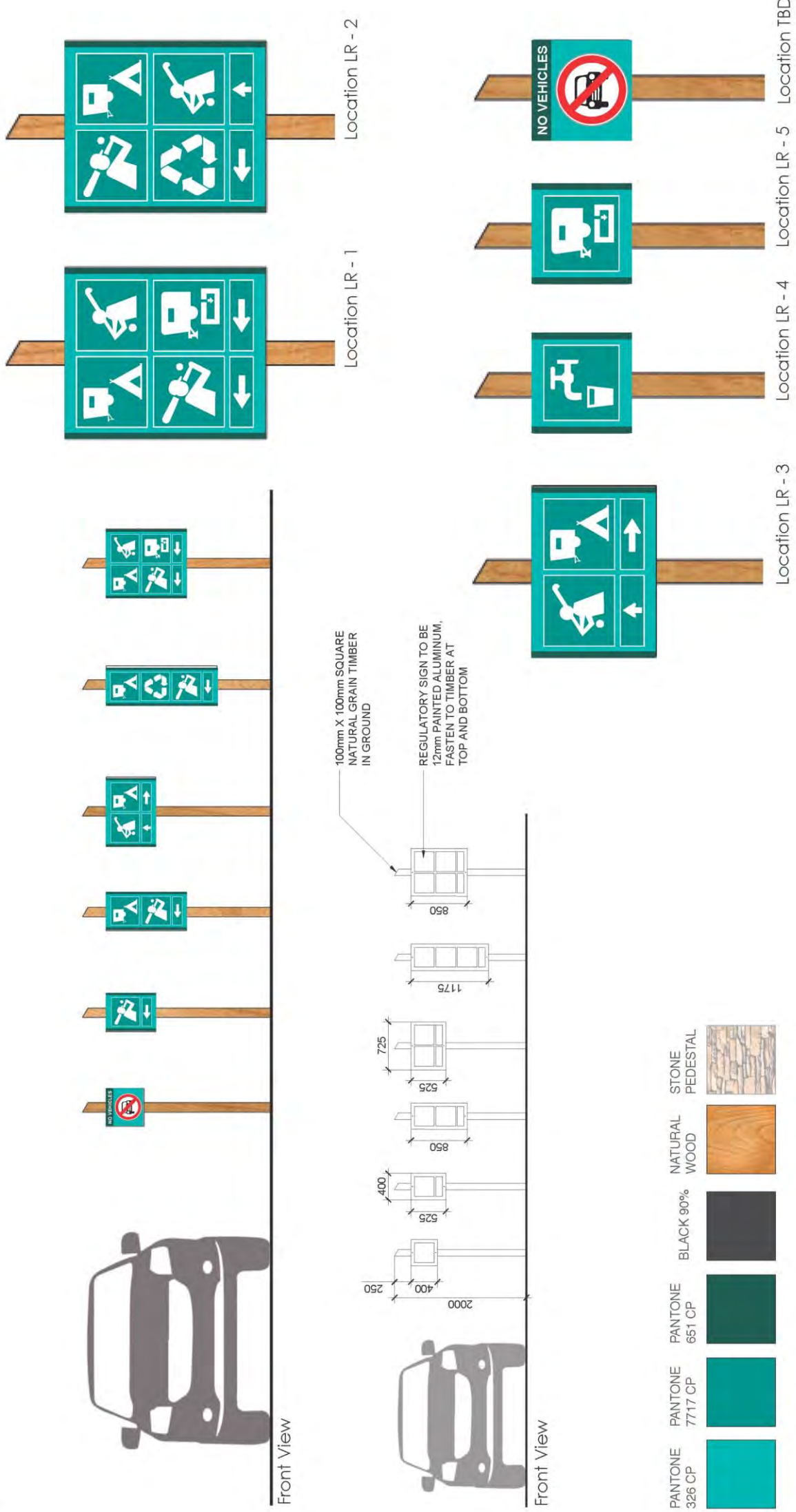

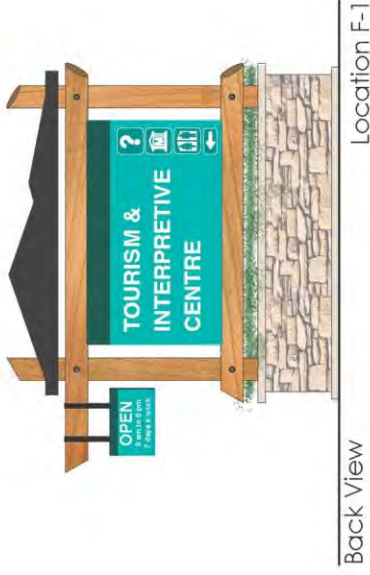
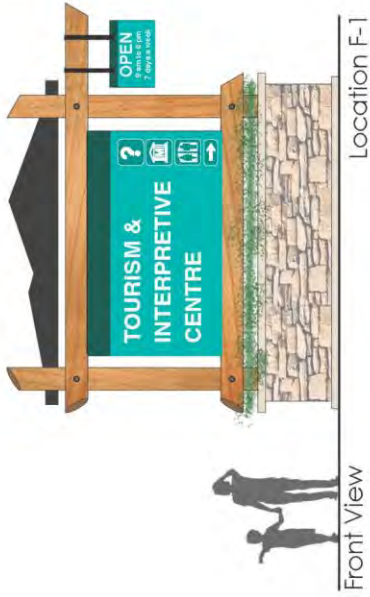

DOUBLE SIDED

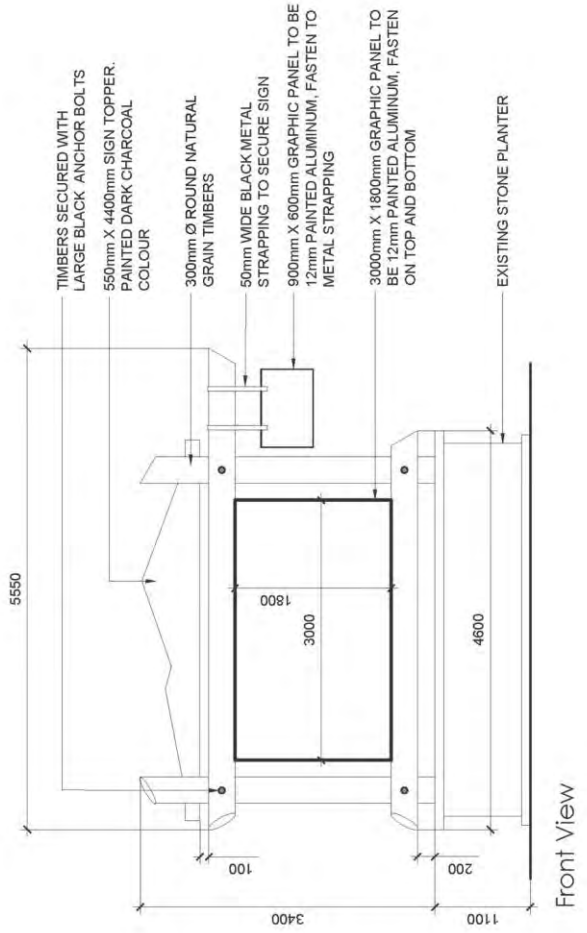

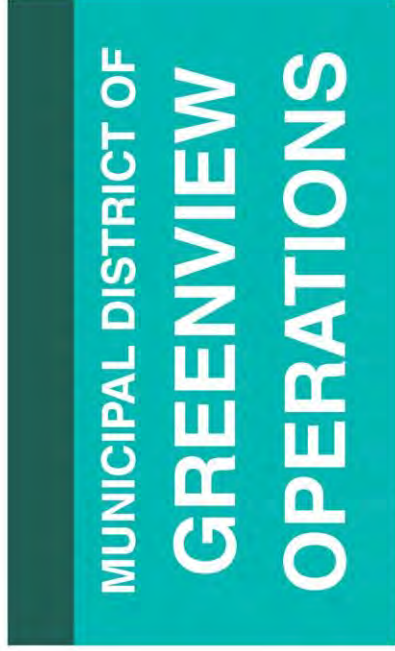
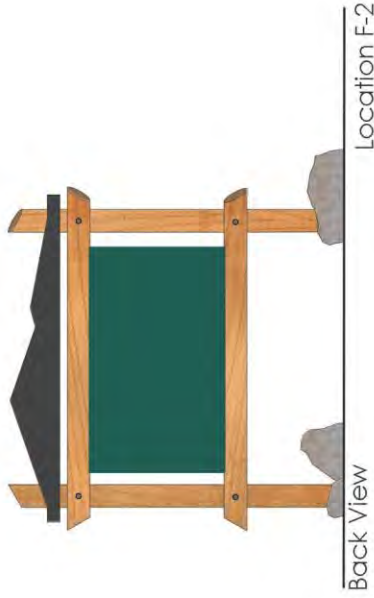

SINGLE SIDED

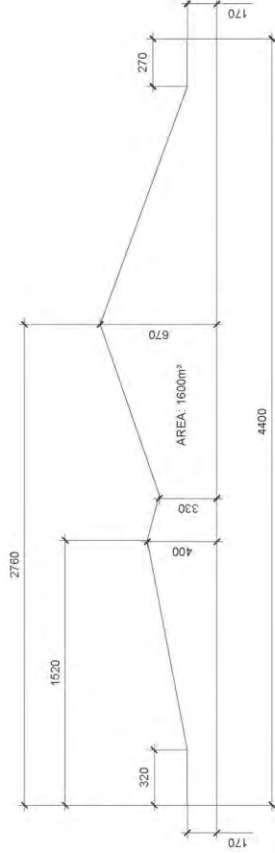
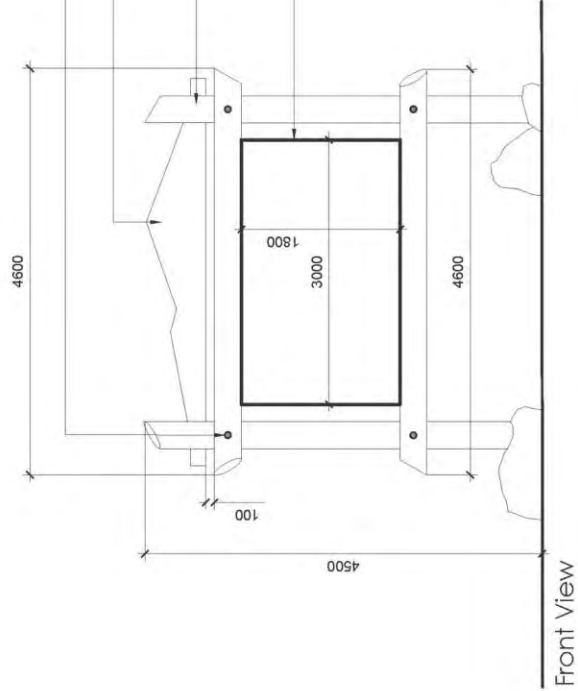

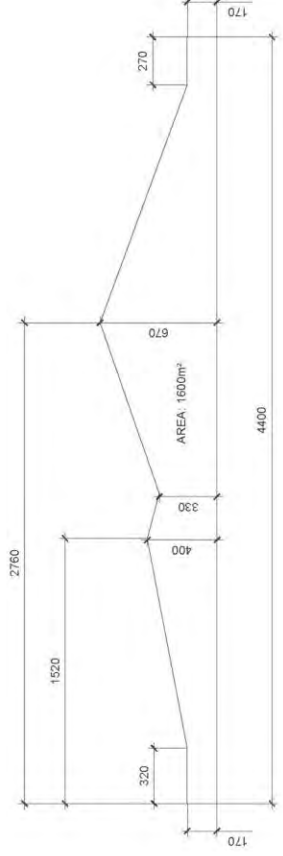
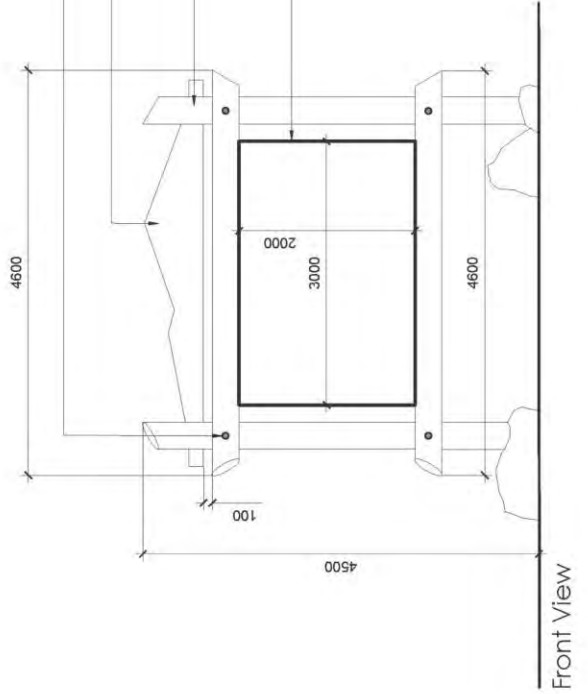
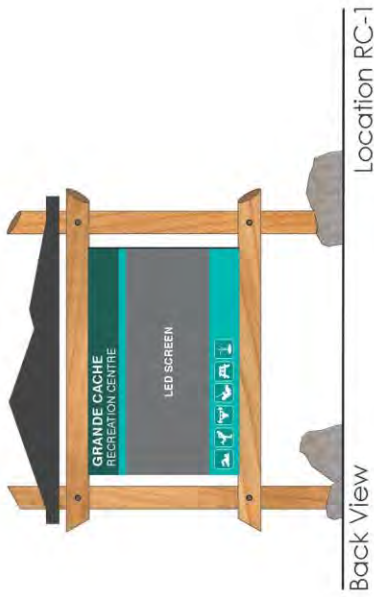

TRAIL SIDE WAYFINDING SIGNAGE

GRANDE CACHE

May 2019

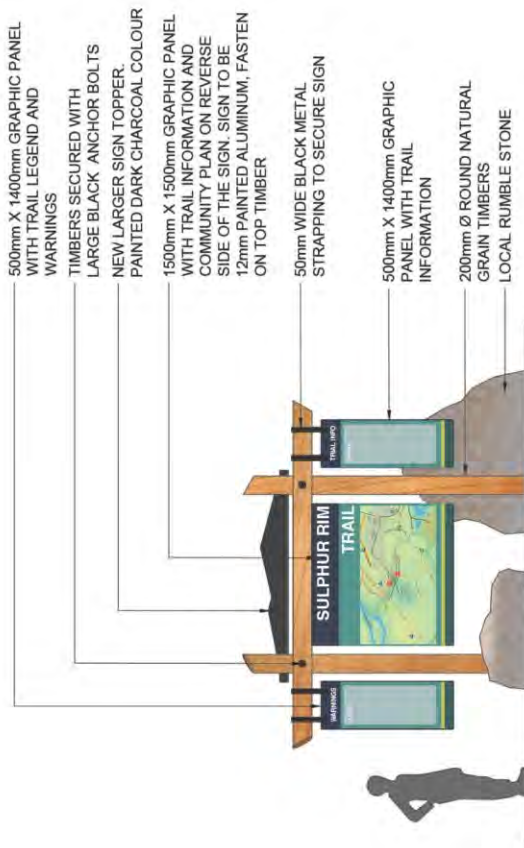

TRAIL HEAD WITH MAPPING



TRAIL ACTIVITY

- MULTI COLOUR CODED TRAIL INFORMATION TO BE 10mm THICK PAINTED ALUMINUM, ALL FOUR SIDES SNUG FIT, BOLTED ONE SIDE
- 200x200mm SQUARE NATURAL GRAIN TIMBER IN GROUND
- PRECAST CONCRETE BOULDERS WITH LOCAL SYMBOLGY STAMPED ON SURFACE



TRAIL AMENITIES

OPTION 1

ALUMINUM	ALUMINUM	ALUMINUM	ALUMINUM	ALUMINUM
ALUMINUM	ALUMINUM	ALUMINUM	ALUMINUM	ALUMINUM
STONE PEDESTAL	STONE PEDESTAL	NATURAL WOOD	NATURAL WOOD	ALUMINUM



TRAIL ENTRANCE

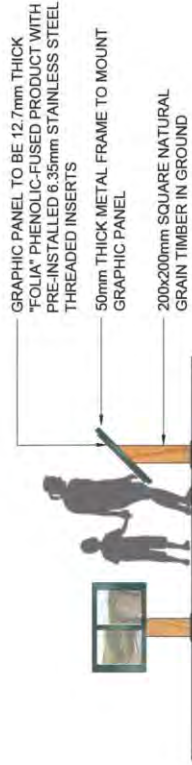

INTERPRETIVE SIGNS

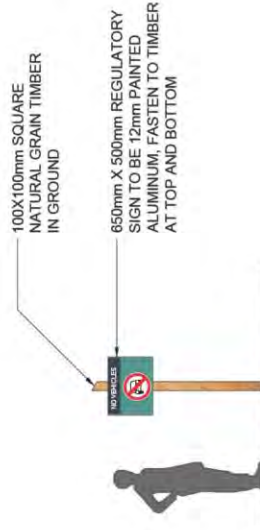

TRAIL REGULATORY SIGNAGE

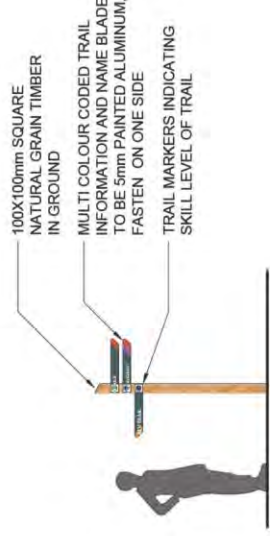

TRAIL NAMES AND MARKERS



TRAIL SKILL AND ACTIVITY LEVEL MARKERS



COMMUNITY PLAN

Grande Cache



TRAIL ETIQUETTE

- Please stay on marked trails.
- Be aware of your surroundings. Keep an eye out for local wildlife.
- Have a mobile device for emergency situations.
- Grande Cache trails are pet friendly. Please keep all pets on a leash and be sure to clean up anything left behind.
- Please place garbage in receptacles provided.
- Do not disturb plants or wildlife.
- Respect the privacy of neighbouring residents.

TRAIL WARNINGS

- Grande Cache will be working closely with the RCMP to patrol area trails. Protective Services will be conducting regular bike patrols to educate and enforce bylaws, as well as to maintain a presence and monitor activities in the areas not easily accessible by motorized vehicles.

MUNICIPAL AMENITIES

1. Town Centre
2. Tourism Centre
3. Campground
4. Cemetery
5. Big Horn Golden Age Club

MUNICIPAL SERVICES

6. Hospital
7. Police
8. Fire Hall
9. Water Treatment Plant
10. Sani Dump

TRAIL HEADS

11. Griffiths Trail Head
12. Sulphur Rim Trail Head

PARKS

13. Jap Park
14. Central Park
15. Labyrinth Park
16. Lions Park Playground
17. Grassy Hill Play Park
18. Birds Eye Park
19. Hamel Park
20. Rocky Raim Park

RECREATION AND SPORT FIELDS

21. Grande Cache Recreation Centre
22. Baseball Diamonds
23. Basketball Court
24. Golf and Country Club
25. GC Saddle Club
26. X-Country Skiing

SCHOOL

27. Sheldon Coates Elementary School
28. Summitview School
29. Grande Cache Community High School
30. Grande Prairie Regional College

CHURCH

31. Cornerstone Mountain Assembly PAOC
32. Lutheran Church Mt Carmel
33. Holy Cross Catholic Church
34. Pineview Alliance Church
35. United Church Canada



EXPAND YOUR VISION
COMMUNITY PLAN

Phased Implementation

- 1) Immediate-term development along Hwy. 40 and to the northeast
- 2) Near-term development at trail heads, along primary trails
- 3) Medium-term development at all facilities, remaining trail signs

Estimated Cost of Implementation

- 1) Immediate-term development along Hwy. 40 and to the northeast
\$8,000 signage; \$18,000 materials; \$14,000 labour = \$40,000
 - 2) Near-term development at trail heads, along primary trails
\$38,000 signage; \$16,000 materials; \$8,000 labour = \$62,000
 - 3) Medium-term development at all facilities, remaining trail signs
\$70,000 signage; \$22,000 materials; \$18,000 labour = \$110,000
- Estimated project total - \$212,000**

Grande Cache Wayfinding Program

Thank you for your participation.

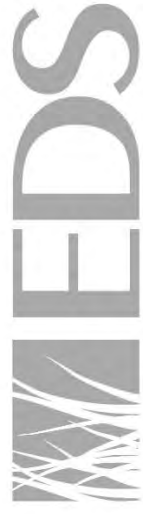

There are no financial implications to the recommended motion.

STAFFING IMPLICATION:

There are no staffing implications to the recommended motion.

PUBLIC ENGAGEMENT LEVEL:

Greenview has adopted the IAP2 Framework for public consultation.

INCREASING LEVEL OF PUBLIC IMPACT

Inform

PUBLIC PARTICIPATION GOAL

Inform - To provide the public with balanced and objective information to assist them in understanding the problem, alternatives, opportunities and/or solutions.

PROMISE TO THE PUBLIC

Inform - We will keep you informed.

FOLLOW UP ACTIONS:

There are no follow up actions to the recommended motion.

ATTACHMENT(S):

- Powers & Associates Appraisal Services Inc. 2019 Presentation

Highlights of the Municipality's Assessment 2014 – 2018 (5 Year Overview)



2018 Assessment Breakdown

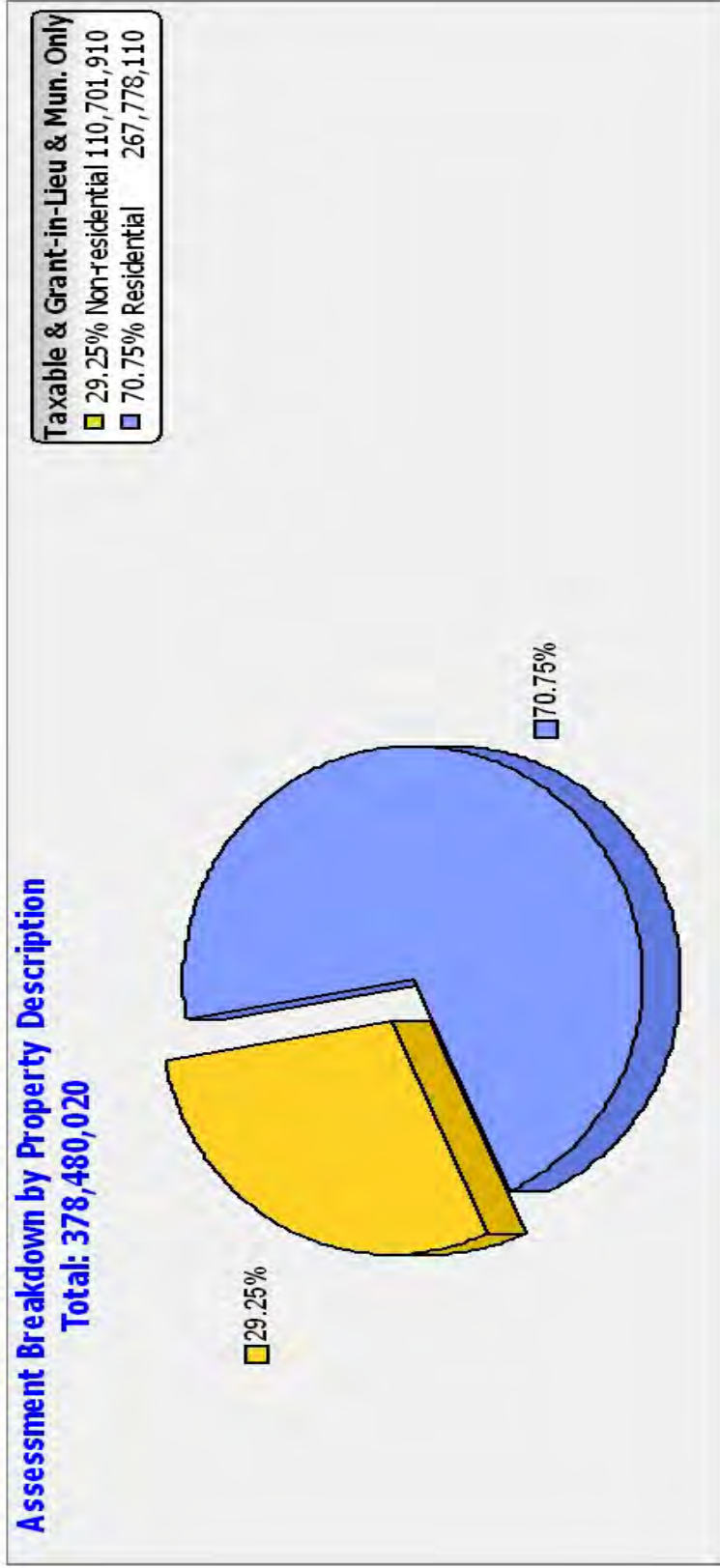

2018 Assessment Breakdown

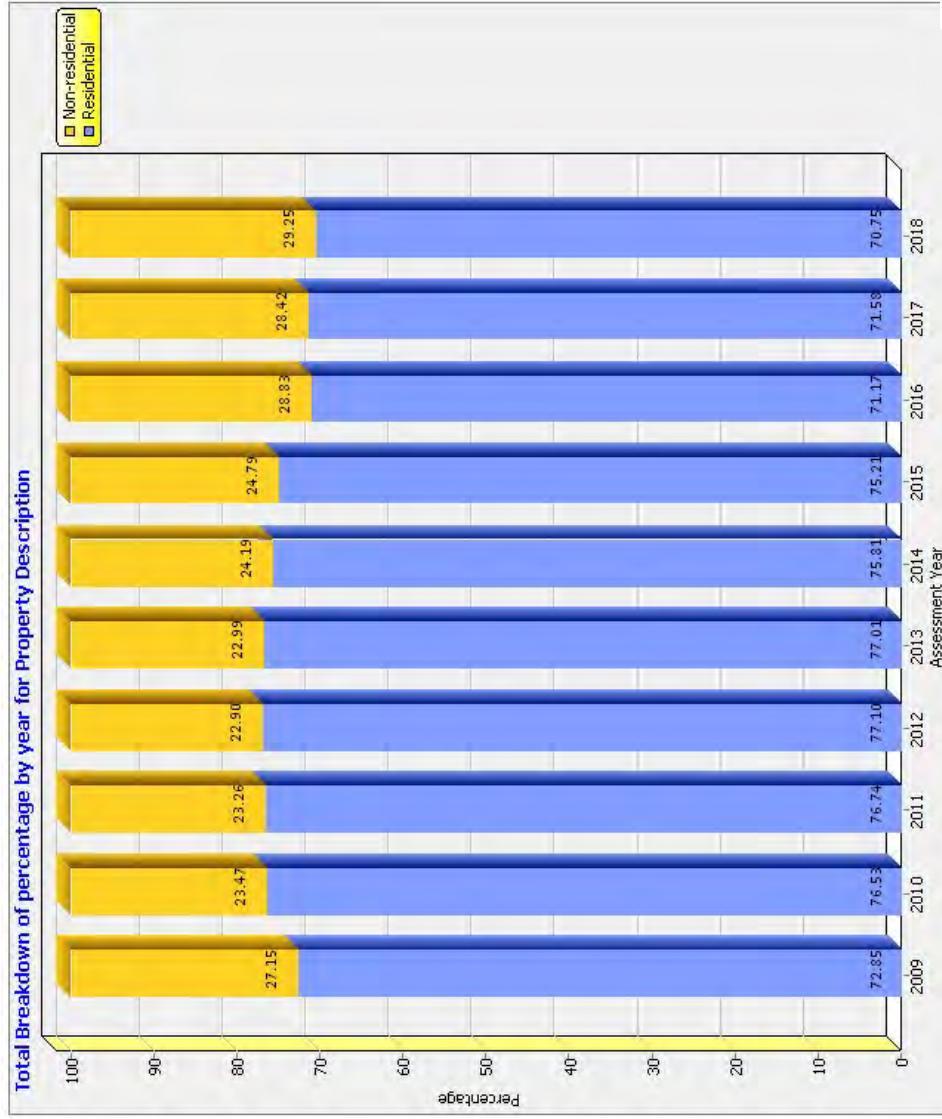

Comparison of Total Taxable Assessment

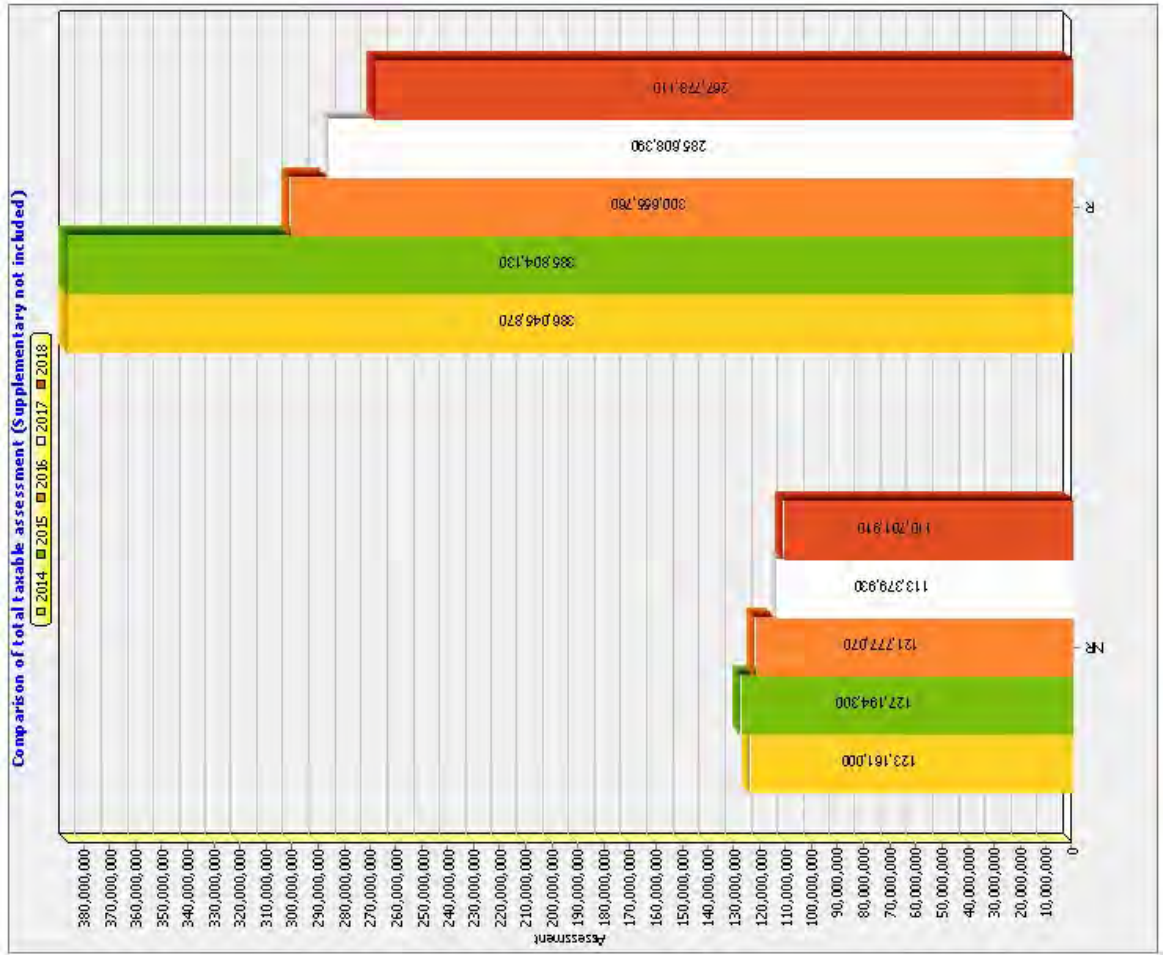

Assessment Total History Comparison

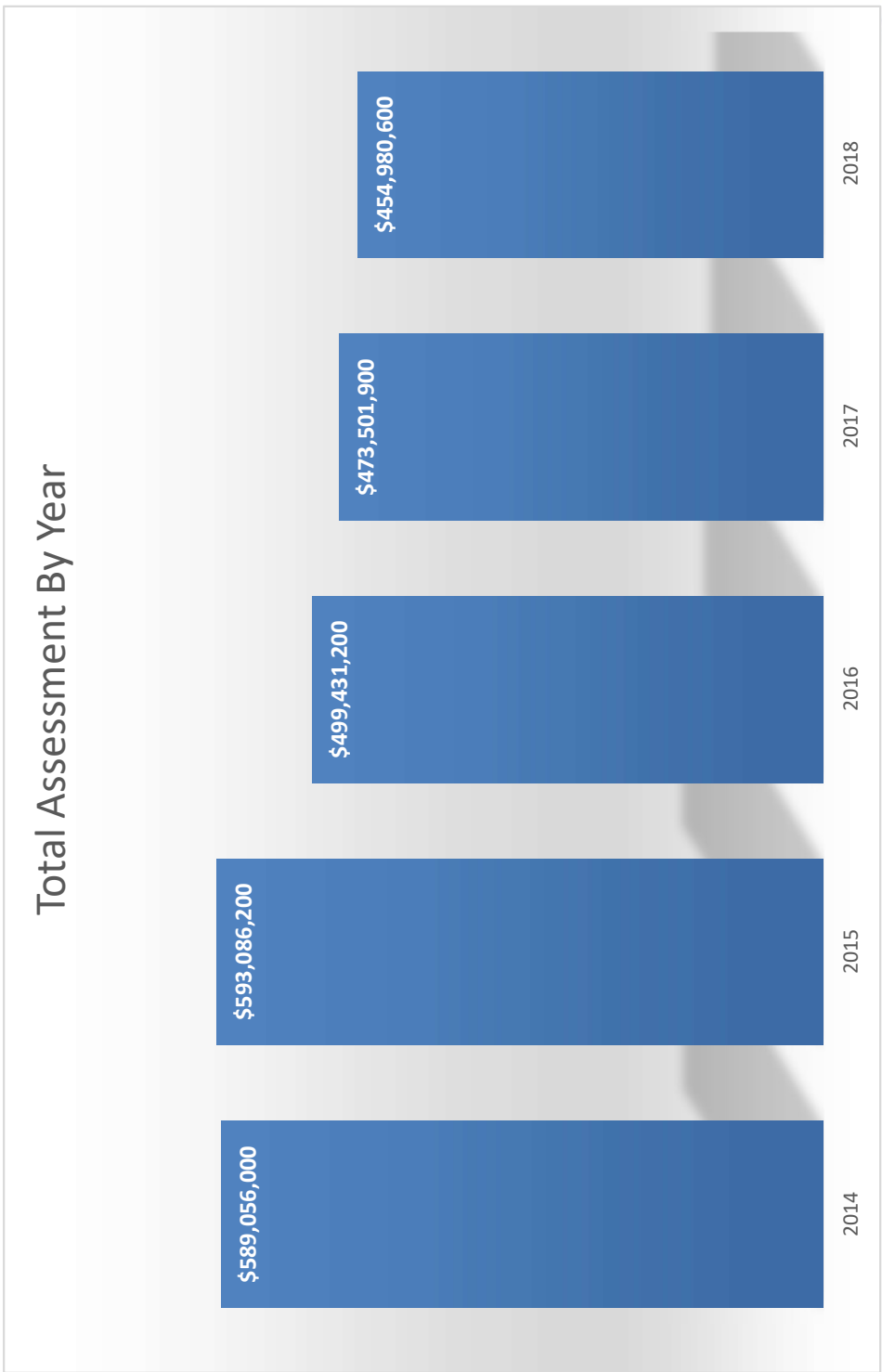

The Big Ones

Code	Description	Records	2014	2015	2016	2017	2018	5 YR CHANGE
2	Residential Improved	1118	\$309,690,130	\$311,112,130	\$239,368,960	\$232,812,940	\$220,671,560	-28.74%
18	Residential Multi Family	6	\$4,398,000	\$4,398,000	\$12,847,000	\$11,360,000	\$9,326,000	112.05%
20	Residential Condominiums	415	\$61,480,000	\$59,943,000	\$39,423,000	\$33,546,000	\$30,620,000	-50.20%
32	* Commercial Impr	56	\$48,203,770	\$47,988,100	\$44,388,630	\$37,724,640	\$36,267,220	-24.76%
42	* Industrial Impr	40	\$18,266,000	\$18,326,000	\$17,915,000	\$15,113,900	\$15,636,900	-14.39%

Residential Improved	49%
Residential Multi Family	2%
Residential Condominiums	7%
* Commercial Impr	8%
* Industrial Impr	3%
OTHER	31%

Breakdown

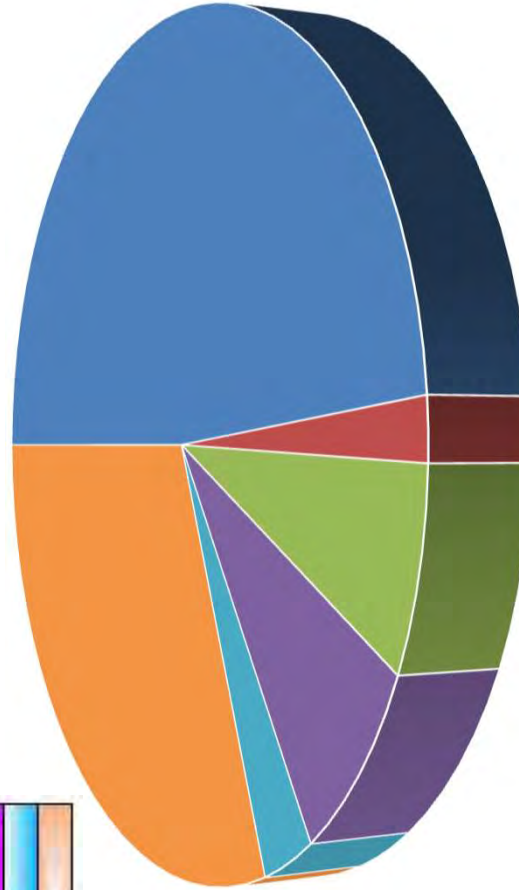

- Residential Improved
- Residential Multi Family
- Residential Condominiums
- * Commercial Impr
- * Industrial Impr
- OTHER



The Big Ones

Code	Description	Records	2014	2015	2016	2017	2018	5 YR CHANGE
2	Residential Improved	1118	\$309,690,130	\$311,112,130	\$239,368,960	\$232,812,940	\$220,671,560	-28.74%
18	Residential Multi Family	6	\$4,398,000	\$4,398,000	\$12,847,000	\$11,360,000	\$9,326,000	112.05%
20	Residential Condominiums	415	\$61,480,000	\$59,943,000	\$39,423,000	\$33,546,000	\$30,620,000	-50.20%
32	* Commercial Impr	56	\$48,203,770	\$47,988,100	\$44,388,630	\$37,724,640	\$36,267,220	-24.76%
42	* Industrial Impr	40	\$18,266,000	\$18,326,000	\$17,915,000	\$15,113,900	\$15,636,900	-14.39%

5 Year Assessment Base Change

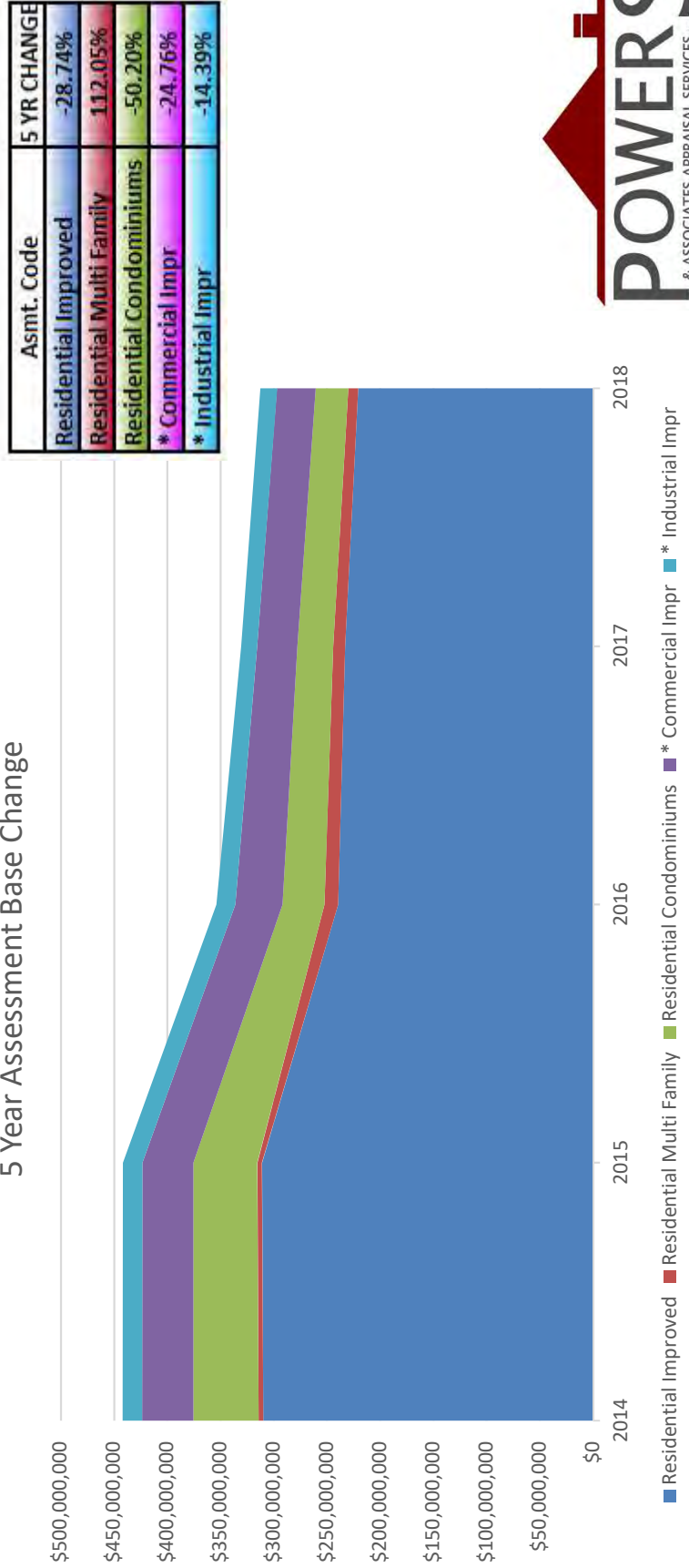

2 – Residential Improved

2014 - 2018 Residential Change

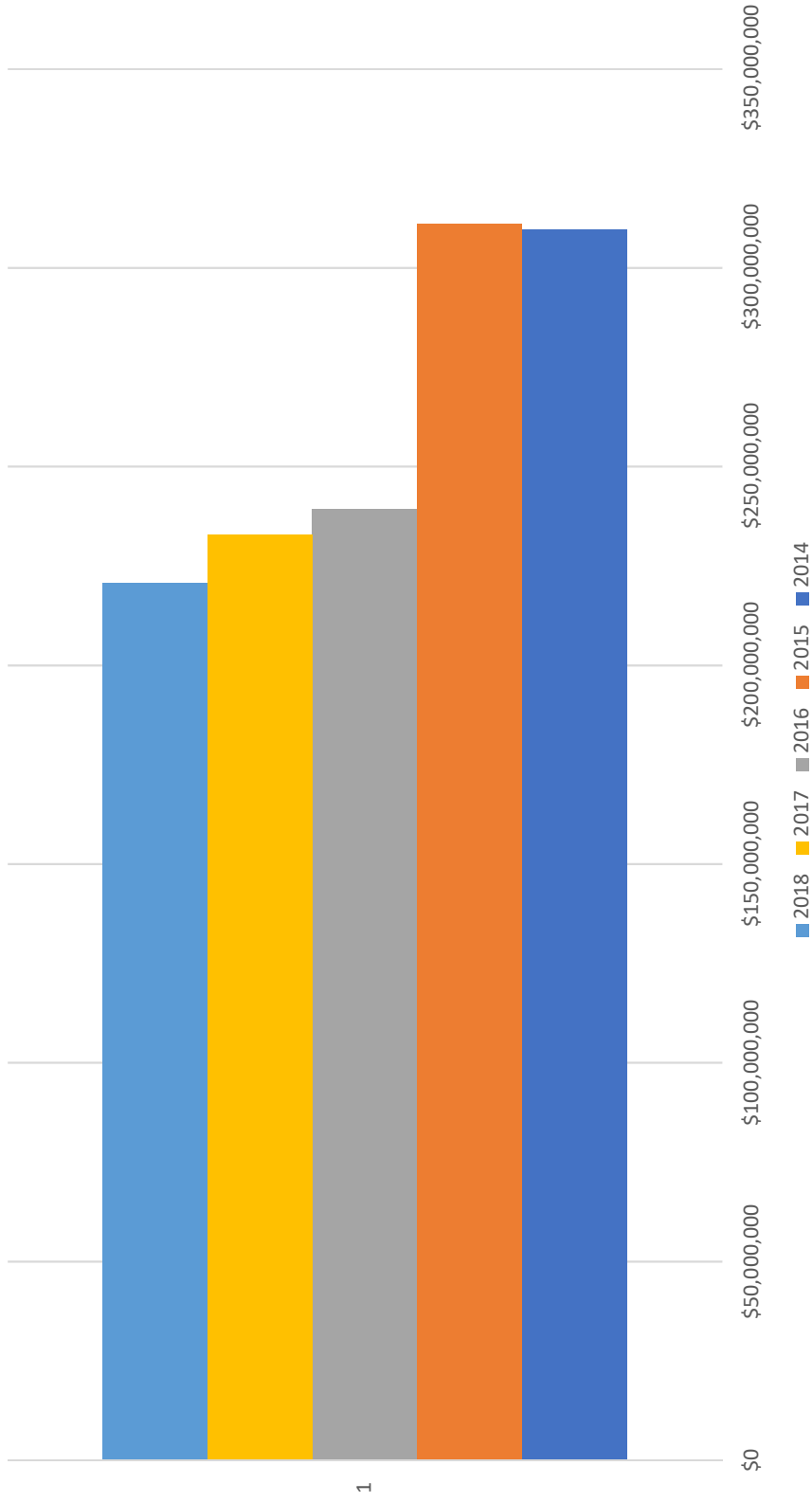

18 – Residential Multi-Family

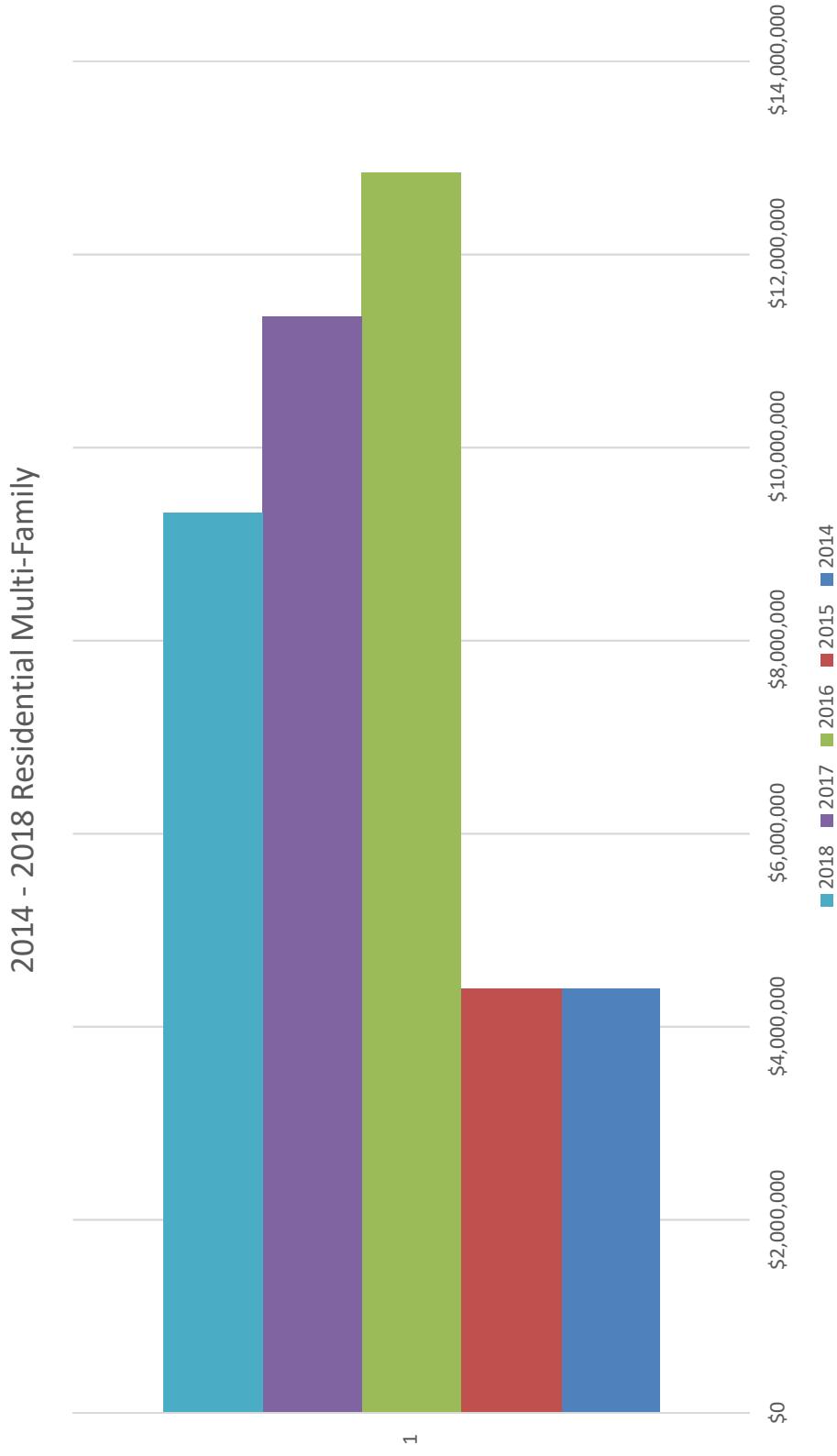

20 – Residential Condominium

2014 - 2018 Condo Change

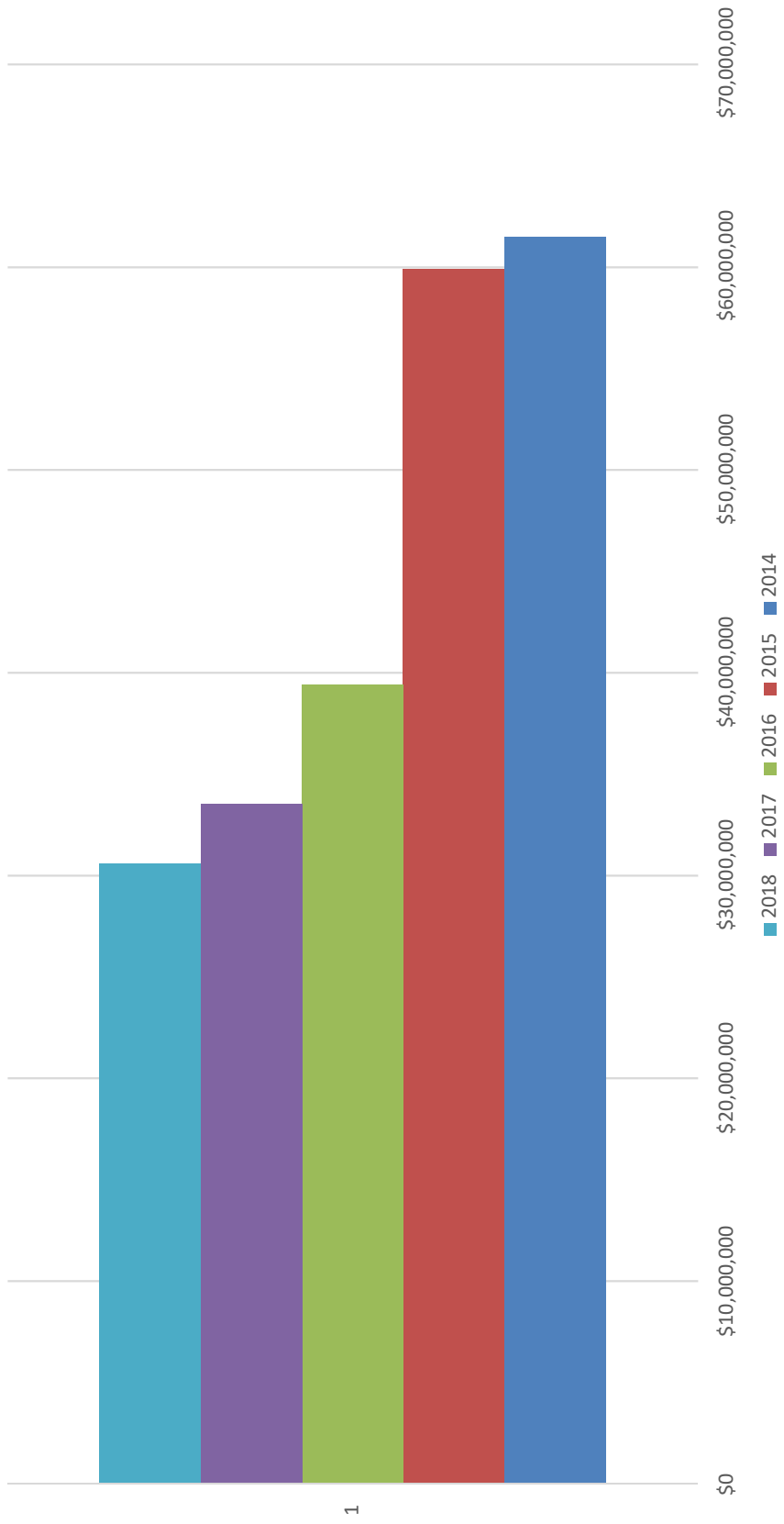

32 – Commercial Improved

2014 - 2018 Improved Commercial Change

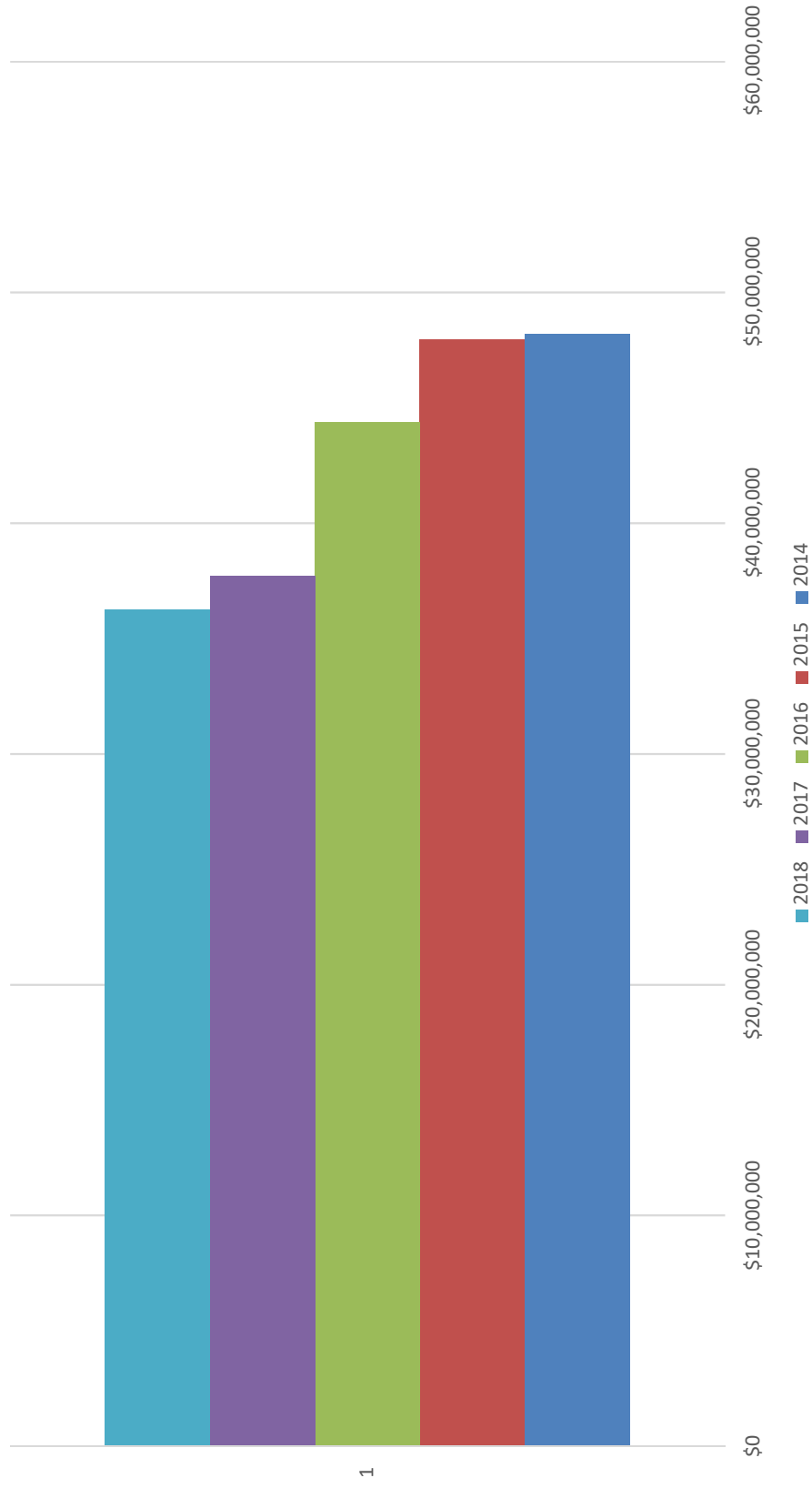

42 – Improved Industrial

2014 - 2018 Improved Industrial Change

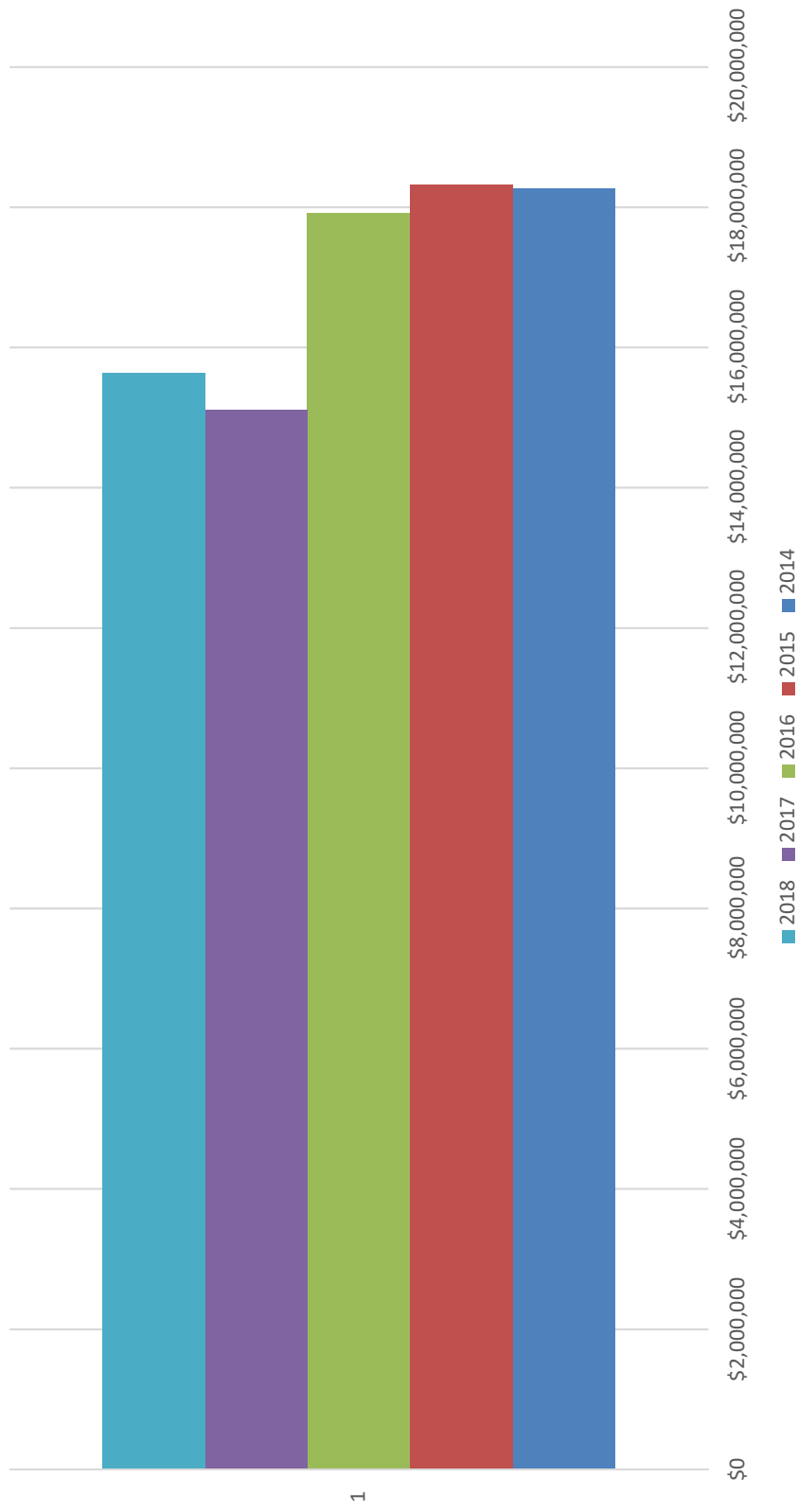

Taxable Assessment Base

Code	Assessment Code	# Parcels	Status	2014 Total	2018 Total	
2	Residential Improved	1118	T	\$309,690,130	\$220,671,560	-29%
8	Motel Residential	3	T	\$170,000	\$104,550	-39%
9	Residential Vacant	44	T	\$2,486,000	\$1,561,000	-37%
12	Mobile Home Park	92	T	\$7,627,000	\$5,425,000	-29%
18	Residential Multi Family	6	T	\$4,398,000	\$9,326,000	112%
20	Residential Condominiums	415	T	\$61,480,000	\$30,620,000	-50%
32	Commercial Impr	56	T	\$48,203,770	\$36,267,220	-25%
33	Commercial Vacant	7	T	\$3,664,000	\$3,109,000	-15%
42	Industrial Impr	40	T	\$18,266,000	\$15,636,900	-14%
43	Industrial Vacant	8	T	\$1,064,000	\$1,107,000	4%





THANK YOU!



REQUEST FOR DECISION

SUBJECT:	Northwest Regional Fire Training Centre		
SUBMISSION TO:	COMMITTEE OF THE WHOLE	REVIEWED AND APPROVED FOR SUBMISSION	
MEETING DATE:	July 15, 2019	CAO:	MANAGER:
DEPARTMENT:	PROTECTIVE SERVICES	GM: SW	PRESENTER: BL
STRATEGIC PLAN:	Regional Cooperation		

RELEVANT LEGISLATION:

Provincial (cite) – N/A

Council Bylaw/Policy (cite) – N/A

RECOMMENDED ACTION:

MOTION: That Committee of the Whole receive the Northwest Regional Fire Training Centre Report for information, as presented.

BACKGROUND/PROPOSAL:

The County of Grande Prairie and the City of Grande Prairie have asked the MD of Greenview to participate in the building and operation of a Regional Training Center for firefighter training. The facility will be located at the Dunes Fire Station within the County of Grande Prairie. The location is adjacent to a fire hall, the County currently has a classroom on site, showers, SCBA fill, laundry, overnight accommodations, training fire engine and a large selection of SCBA that could be utilized by all agencies.

This working group is asking for a capital investment of \$500,000.00 over two budget years, 2020 and 2021. With a total capital cost of \$ 1,500,000.00 to be divided equally by the three Municipalities. Greenview firefighters would be able to train at this facility free of charge while utilizing our own training staff.

Administration is considering the following factors for determining the benefit of contributing to this facility:

- The \$500,000.00 building commitment is a heavy cost for training.
- Training on an annual basis equals approximately \$70,000.00 - \$80,000.00 per year for all fire departments within Greenview. Administration does not have sufficient information to assess that a cost savings will result once the training facility is built and operational.
- The facility will result in operational expenses associated with the building and the yard site, maintenance costs and future capital replacement costs. The annual cost of these expenses is anticipated to be \$10,000.00 to \$15,000.00 per municipality. A calendar will be established for booking the facility. Planned training arrangements might conflict with the other municipalities. The working group is planning to generate revenue which could be put into reserve for the facility, with hopes of making the operations cost neutral.
- The facility is located in the County of Grande Prairie, therefore our departments will be required to drive to the facility (mileage cost associated) and there will be meal costs.

- Greenview Firefighters would have better access to mandatory training.
- Greenview Firefighters would have a training Centre close by, and therefore reduce travel and training costs.

BENEFITS OF THE RECOMMENDED ACTION:

1. The benefit of the recommended motion is that Council will be informed of the proposed regional training Centre and the concerns.

DISADVANTAGES OF THE RECOMMENDED ACTION:

1. There are no disadvantages to the recommended motion.

ALTERNATIVES CONSIDERED:

1. Council has the alternative to not accept the recommended motion for information.

FINANCIAL IMPLICATION:

There are no financial implications to the recommended motion.

STAFFING IMPLICATION:

There are no staffing implications to the recommended motion.

PUBLIC ENGAGEMENT LEVEL:

Greenview has adopted the IAP2 Framework for public consultation.

INCREASING LEVEL OF PUBLIC IMPACT

Inform

PUBLIC PARTICIPATION GOAL

Inform - To provide the public with balanced and objective information to assist them in understanding the problem, alternatives, opportunities and/or solutions.

PROMISE TO THE PUBLIC

Inform - We will keep you informed.

FOLLOW UP ACTIONS:

There are no follow up actions to the recommended motion.

ATTACHMENT(S):

- Northwest Regional Fire Training Centre Working Group Notes

Northwest Regional Fire Training Centre

Working Group

Deputy Chief- Operations: Trevor Grant GPFD

Fire Services Coordinator MD of Greenview: Brian Lott GCFD

Deputy Chief- Training/ Logistics: Jason Nesbitt CGPRFS

Chief Training Officer: Neal Young GPFD

Captain: Mike Shykora CGPRFS

<p>1. Background</p>	<ul style="list-style-type: none"> ✓ <i>For many years fire departments in the region have had very few opportunities for live fire training at a local Level. There have been numerous barriers to training from travel distances to realism to health & safety. Through cooperation from the City of Grande Prairie, County of Grande Prairie and Municipal District of Greenview a safe, efficient and effective training facility is more than attainable.</i>
<p>2. Objectives</p>	<ul style="list-style-type: none"> ✓ <i>Establish a committee to conduct a needs assessment</i> ✓ <i>Complete a “terms of reference” document associated with a proposed regional fire training facility</i> ✓ <i>Identify the training needs of all stakeholders</i> ✓ <i>Identify the appropriate location for a regional training facility</i> ✓ <i>Provide an overview of the total budgetary implications of constructing a regional fire training facility.</i> ✓ <i>Investigate possible funding sources to make the regional facility a success</i>
<p>3. Issues</p>	<ul style="list-style-type: none"> ✓ <i>Funding Models</i> ✓ <i>Regional cooperation (elected officials)</i> ✓ <i>Management of the facility</i> ✓ <i>Maintenance of the facility</i> ✓ <i>Standard Operating Procedures (SOP’s)</i> ✓ <i>Key responsibilities of regional partners</i> ✓ <i>Use of the facility by outside agencies</i> ✓ <i>Scale of facility i.e. IFSAC/ProBoard NFPA 1001 programs</i>
<p>4. Methodology</p>	<ul style="list-style-type: none"> ✓ <i>What are the training needs (JPR’s) of stakeholder agencies?</i> ✓ <i>What are the statutory requirements of regional cooperation</i> ✓ <i>What are the statutory obligations of building the facility (permits, NFPA 1402 etc.)</i> ✓ <i>What does a cooperative funding model look like? (%)</i> ✓ <i>Site preparation phase?</i> ✓ <i>Structure building phase</i> ✓ <i>Ancillary prop installation phase</i> ✓ <i>Facility commissioning</i>
<p>5. Expertise</p>	<ul style="list-style-type: none"> ✓ <i>Building & Fire Safety Codes Officers</i> ✓ <i>NFPA 1041/1403 Fire Service Instructors</i> ✓ <i>Vendors</i> ✓ <i>Department SME’s</i> ✓ <i>Outside agencies with experience/knowledge of regional training facilities.</i> ✓ <i>This working group</i>
<p>6. Reporting</p>	<ul style="list-style-type: none"> ✓ <i>Assign action items to members in the working group</i> ✓ <i>After action items are assigned the reporting structure should likely be back to the working group and then up the chain to the Chief Officers’ of the respective agencies.</i> ✓ <i>Set submission dates</i> ✓ <i>Once a solid business case is in place the working group should present the business case to a group of Chief Officer’s from the responsible agencies. (Fire Chiefs, Directors, etc.)</i>
<p>7. Work plan</p>	<ul style="list-style-type: none"> ✓ <i>A document of the JPR’s or certification levels required needs to be drafted</i> ✓ <i>A list of facilities and/or props required is a necessity</i> ✓ <i>A timeline of needs and trigger points has to be written</i> ✓

Date	Chief Administrative Officer Action Log	Responsible Party	NOTES/STATUS
19 07 08 RC Meeting			
July 8, 2019	<p>MOTION: 19.07.521. Moved by: COUNCILLOR ROXIE RUTT That Council give Third Reading to Bylaw 19-816 "Schedules of Fees Bylaw."</p> <p>Councillor Tom Burton abstained from voting on Third Reading of Bylaw 19-816 Schedules of Fees. CARRIED</p>		Complete
July 8, 2019	<p>MOTION: 19.07.522. Moved by: COUNCILLOR DALE GERVAIS That Council approve the donation of the used digital communications tools to non-profit organizations until August 26, 2019; followed by an opportunity for Council Members and Greenview staff to purchase any remaining digital communications tools until September 23rd, 2019; after which any remaining items may be disposed of by Administration. CARRIED</p>	Corp. Serv.	End Sept.
July 8, 2019	<p>MOTION: 19.07.523. Moved by: COUNCILLOR TYLER OLSEN That Council approve \$3,200 + G.S.T. to complete an appraisal on Camp Hide A Way, with funds to come from Economic Development. CARRIED</p>		
July 8, 2019	<p>MOTION: 19.07.524. Moved by: COUNCILLOR TOM BURTON That Council authorize Administration to transfer \$3,200 + G.S.T. from Contingency Reserve to Economic Development Budget. CARRIED</p>	Corp. Serv.	Complete
July 8, 2019	<p>MOTION: 19.07.525. Moved by: COUNCILLOR SHAWN ACTON That Council approve Administration to increase the HDPE water pipe line from 100 mm to 150 mm on the Valleyview Rural Waterline extension down Twp. 700 road to ensure adequate supply for future connections, \$41,000.00 for the Valleyview Rural Waterline Extension. CARRIED</p>		
July 8, 2019	<p>MOTION: 19.07.526. Moved by: COUNCILLOR DUANE DIDOW That Council approve Administration to transfer an additional \$41,000.00 from water reserves to the 2019 Capital Budget for Valleyview Rural Waterline Extension. CARRIED</p>	Corp. Serv.	Complete
July 8, 2019	<p>MOTION: 19.07.527. Moved by: REEVE DALE SMITH That Council approve an operating grant in the amount of \$4,000.00 to the Alberta Stock Dog Association, to be used to host the 2019 Western Canadian Stock Dog Championship in Valleyview Alberta, with funds to come from the 2019 Community Services Miscellaneous Grant. CARRIED</p>		

July 8, 2019	MOTION: 19.07.528. Moved by: COUNCILLOR ROXIE RUTT That Council accept the request for sponsorship from the Aseniwuche Winewak Nation for the 3rd Annual Memorial Round Dance to be held in Grande Cache Alberta, for information, as presented. CARRIED		
July 8, 2019	MOTION: 19.07.529. Moved by: COUNCILLOR DALE GERVAIS That Council sponsor the Aseniwuche Winewak Nation for the 3rd Annual Memorial Round Dance to be held in Grande Cache Alberta for \$5,225.00 and \$125.00 of Greenview Merchandise with funds to come from Community Services Miscellaneous Grants. CARRIED		
July 8, 2019	MOTION: 19.07.530. Moved by: Choose an item. That Council take no action on the request from Total Oilfield Ltd. to reverse finance charges on AR Account# 186203 in the amount of \$1,167.84 CARRIED	Corp. Serv.	In progress complete July 15, 2019
July 8, 2019	MOTION: 19.07.531. Moved by: COUNCILLOR SHAWN ACTON That Council take no action on the request from Seven Generations Energy Ltd to reverse finance charges on their A/R Account for \$120,178.27. CARRIED	Corp. Serv.	In progress complete July 15, 2019
July 8, 2019	MOTION: 19.07.532. Moved by: COUNCILLOR DALE GERVAIS That Council approve revised Policy 1014 "Request for Decision". CARRIED		Complete
July 8, 2019	MOTION: 19.07.533. Moved by: COUNCILLOR ROXIE RUTT That Council approve Policy 1003 "Vehicle Usage" as amended; • 4.2.10 – remove "Except under the following circumstances: a. in situations where the vehicle will be stopped for less than 1 minute. In these cases, it is the drivers responsibility to ensure that the vehicle is placed in park." CARRIED		Complete
July 8, 2019	MOTION: 19.07.534. Moved by: DEPUTY REEVE WINSTON DELORME That Council approve Policy 4022 "Commercial Waste Bins" as presented.		
July 8, 2019	MOTION: 19.07.525. Moved by: COUNCILLOR TOM BURTON That Council refer motion 19.07.534. Commercial Waste Bins until a future Regular Council Meeting. CARRIED		
July 8, 2019	MOTION: 19.07.536. Moved by: COUNCILLOR DUANE DIDOW That Council approve Policy 1030 "Flag Protocol" as presented. CARRIED		Complete

July 8, 2019	MOTION: 19.07.537. Moved by: COUNCILLOR ROXIE RUTT That Council for approve Policy 1001 "Policy Development" as presented. CARRIED		Complete
July 8, 2019	MOTION: 19.07.538. Moved by: COUNCILLOR TOM BURTON That Council approve Policy 1504 "Accounts Receivable Cancellation or Adjustments" as presented. CARRIED		Complete
July 8, 2019	MOTION: 19.07.539. Moved by: COUNCILLOR DUANE DIDOW That Council repeal Policy AD 34 "Accounts Receivable Cancellation or Adjustments". CARRIED		Complete
July 8, 2019	MOTION: 19.07.540. Moved by: COUNCILLOR DALE GERVAIS That Council approve a new position in the Infrastructure and Planning Department for a Fleet and Procurement Coordinator. CARRIED		
July 8, 2019	MOTION: 19.07.541. Moved by: DEPUTY REEVE WINSTON DELORME That Council authorize funding to the scholarship recipients in the amounts indicated on the 2019 Scholarship Recommendation Listing, with funds to come from the Community Service Budget. CARRIED		
July 8, 2019	MOTION: 19.07.542. Moved by: COUNCILLOR DALE GERVAIS That Council appoint Judy Rieu to the Sunset House Cemetery Committee. CARRIED		Complete
July 8, 2019	Councillor Dale Gervais declared a Notice of Motion. That Council direct Administration to add Councillors Expense Claims to future Council Meeting agendas.		
July 8, 2019	MOTION: 19.07.548. Moved by: COUNCILLOR SHAWN ACTON That Council repeal motion 19.06.490, Second Reading of Bylaw 19-815. CARRIED		Complete
July 8, 2019	MOTION: 19.07.549. Moved by: COUNCILLOR DALE GERVAIS That a public hearing for Bylaw 19-815, the Tri-Municipal Industrial Partnership ASP, be scheduled for August 26, 2019 at 10:00 am. CARRIED		
19 06 24 RC Meeting			
June 24, 2019	MOTION: 19.06.479. Moved by: COUNCILLOR DALE GERVAIS That Council award SMS Equipment, Grande Prairie, AB the 2019 Wheel Loader Tender in the amount of \$306,227.00, with funds to come from the approved Grande Cache Capital budget. CARRIED		

June 24, 2019	MOTION: 19.06.480. Moved by: COUNCILLOR DUANE DIDOW That Council transfer additional funding in the amount of \$26,227.00 for the purchase of the Wheel Loader, from Equipment and Fleet Reserves, to the 2019 Grande Cache Capital budget. CARRIED	Corp. Serv.	Complete
June 24, 2019	MOTION: 19.06.481. Moved by: COUNCILLOR DALE GERVAIS That Council award Dematco of Acheson, AB the Service Truck Body purchase for the amount of \$69,990.00. Funds to come from the Equipment and Fleet Reserve. CARRIED		
June 24, 2019	MOTION: 19.06.482. Moved by: COUNCILLOR ROXIE RUTT That Council approve \$23,000 for the purchase of Tools for the Service Truck with funds to come from the Equipment and Fleet Reserve. CARRIED	Corp. Serv.	Complete
June 24, 2019	MOTION: 19.06.484. Moved by: COUNCILLOR TYLER OLSEN That Council award CALCO Equipment Inc. of Edmonton, AB the 2019 Telescopic Articulating Bucket Truck Tender for the amount of \$158,675.00, with funds to come from the approved 2019 Capital budget for Grande Cache. CARRIED		
June 24, 2019	MOTION: 19.06.485. Moved by: COUNCILLOR SHAWN ACTON That Council authorize Administration to evenly distribute to the Valleyview, Fox Creek, Grande Cache and Grande Prairie Food Banks the funds raised from the 2019 Clay Shoot Tournament. CARRIED		
June 24, 2019	MOTION: 19.06.490. Moved by: COUNCILLOR DALE GERVAIS That Council give Second Reading to Bylaw 19-815 for the Tri-Municipal Industrial Partnership Area Structure Plan. CARRIED	Com. Serv.	Complete
June 24, 2019	MOTION: 19.06.491. Moved by: DEPUTY REEVE WINSTON DELORME That Council approve a Capital Grant in the amount of \$25,000.00 and an Operating Grant in the amount of \$12,500.00 to the Grande Cache Golf and Country Club, with funds to come from Community Service Miscellaneous Grant. CARRIED	Com. Serv.	Complete
June 24, 2019	MOTION: 19.06.495. Moved by: COUNCILLOR ROXIE RUTT That Council direct Administration to reallocate \$650,000.00 from the Unrestricted Reserve to Salaries and Employer Contributions to fund the approved compensation increases retroactive to Jan 1st, 2019. CARRIED	Corp. Serv.	In progress

June 24, 2019	MOTION: 19.06.496. Moved by: COUNCILLOR SHAWN ACTON That Council endorse the proposed RMA Resolution: "Utility Distribution Rates in Rural and Northern Communities and Commercial Rates for Public Facilities" CARRIED		
June 24, 2019	MOTION: 19.06.497. Moved by: COUNCILLOR ROXIE RUTT That Council endorse the proposed RMA Resolution "AER Setback Referrals for Development near Sour Gas Facilities" to be presented at the RMA Zone 4 Meeting. CARRIED		
June 24, 2019	MOTION: 19.06.498. Moved by: COUNCILLOR LES URNESS That Council for approve Policy 6318 "Private Land Herbicide Applications" as presented. CARRIED		Complete
June 24, 2019	MOTION: 19.06.499. Moved by: DEPUTY REEVE WINSTON DELORME That Council repeal Policy AG 14 "Private Land Herbicide Application". CARRIED		Complete
June 24, 2019	MOTION: 19.06.500. Moved by: COUNCILLOR DALE GERVAIS That Council approve Policy 6316 "Pest Control" as presented. CARRIED	CAO/Com. Serv.	Complete
June 24, 2019	MOTION: 19.06.501. Moved by: DEPUTY REEVE WINSTON DELORME That Council repeal Policy AG 04 "Pest Control". CARRIED	CAO/Com. Serv.	Complete
June 24, 2019	MOTION: 19.06.502. Moved by: DEPUTY REEVE WINSTON DELORME That Council approve Policy 6319 "Pest Surveillance and Reporting" as presented. CARRIED	CAO/Com. Serv.	Complete
June 24, 2019	MOTION: 19.06.503. Moved by: COUNCILLOR SHAWN ACTON That Council repeal Policy AG 15 "Pest Surveillance and Reporting". CARRIED	CAO/Com. Serv.	Complete
June 24, 2019	MOTION: 19.06.504. Moved by: COUNCILLOR DUANE DIDOW That Council approve Policy 6317 "Spray Exemptions" as presented. CARRIED	CAO/Com. Serv.	Complete
June 24, 2019	MOTION: 19.06.505. Moved by: COUNCILLOR ROXIE RUTT That Council repeal Policy AG 13 "Spray Exemptions". CARRIED	CAO/Com. Serv.	Complete
June 24, 2019	MOTION: 19.06.506. Moved by: COUNCILLOR DALE GERVAIS That Council approve Policy 6315 "Farm Family Awards" as presented. CARRIED	CAO/Com. Serv.	Complete

June 24, 2019	MOTION: 19.06.507. Moved by: COUNCILLOR DUANE DIDOW That Council repeal Policy AG 03 "Farm Family Awards". CARRIED	CAO/Com. Serv.	Complete
June 24, 2019	<p>MOTION: 19.06.508. Moved by: COUNCILLOR TYLER OLSEN That Council set the terms and conditions that apply to the public sale of land as per the attached advertisement and adopt the "Opinion of Value" prepared by Powers & Associates with reserve bid prices as follows:</p> <p>Roll #520001 Plan 0925042 Unit 1 Opinion \$30,000.00 Roll #520002 Plan 0925042 Unit 2 Opinion \$40,000.00 Roll #520003 Plan 0925042 Unit 3 Opinion \$55,000.00 Roll #520005 Plan 0925042 Unit 5 Opinion \$40,000.00 Roll #520006 Plan 0925042 Unit 6 Opinion \$40,000.00 Roll #520008 Plan 0925042 Unit 8 Opinion \$50,000.00 Roll #520009 Plan 0925042 Unit 9 Opinion \$50,000.00 Roll #520010 Plan 0925042 Unit 10 Opinion \$80,000.00 Roll #392111 Plan 0425096 Block 38 Lot 12 Opinion \$245,000.00 Roll #26163012 Plan 0728033 Unit 12 Opinion \$5,000.00</p> <p>CARRIED</p>		
June 24, 2019	<p>MOTION: 19.06.509. Moved by: COUNCILLOR DUANE DIDOW That Council set September 18, 2019 at 1:15 p.m. Mountain Standard Time as the Public Auction Date for the sale of the following properties:</p> <p>Roll #520001 Plan 0925042 Unit 1 Opinion \$30,000.00 Roll #520002 Plan 0925042 Unit 2 Opinion \$40,000.00 Roll #520003 Plan 0925042 Unit 3 Opinion \$55,000.00 Roll #520005 Plan 0925042 Unit 5 Opinion \$40,000.00 Roll #520006 Plan 0925042 Unit 6 Opinion \$40,000.00 Roll #520008 Plan 0925042 Unit 8 Opinion \$50,000.00 Roll #520009 Plan 0925042 Unit 9 Opinion \$50,000.00 Roll #520010 Plan 0925042 Unit 10 Opinion \$80,000.00 Roll #392111 Plan 0425096 Block 38 Lot 12 Opinion \$245,000.00 Roll #26163012 Plan 0728033 Unit 12 Opinion \$5,000.00</p> <p>CARRIED</p>		

<p>June 24, 2019</p>	<p>MOTION: 19.06.510. Moved by: COUNCILLOR DALE GERVAIS That Council set the terms and conditions that apply to the public sale of land as per the attached advertisement and adopt the "Opinion of Value" prepared by Accurate Assessment Group with reserve bid prices as follows:</p> <p>Roll #178997 NW-16-71-22-W5 Opinion \$165,000 Roll #178998 SW-16-71-22-W5 Opinion \$120,000 Roll #309426 SW-6-69-6-W6, Plan 03222694, Block 1, Lot 2 Opinion \$315,000 Roll #309587 SW-3-69-7-W6, Plan 0525878 Block 1, Lot 1 Opinion \$435,000 Roll #311066 SW-26-65-21-W5, Plan 9820795, Lot 1 Opinion \$60,000 Roll #311097 SE-14-69-8-W6, Plan 9825458, Lot 1 Opinion \$325,000 Roll #317447 SW-5-70-6-W6, Plan 1124095, Block 1, Lot 5 Opinion \$495,000 Roll #37908 NE-16-71-22-W5 Opinion \$120,000</p> <p>CARRIED</p>		
<p>June 24, 2019</p>	<p>MOTION: 19.06.511. Moved by: REEVE DALE SMITH That Council set September 18, 2019 at 1:15 p.m. Mountain Standard Time as the Public Auction Date for the sale of the following properties:</p> <p>Roll #178997 NW-16-71-22-W5 Opinion \$165,000 Roll #178998 SW-16-71-22-W5 Opinion \$120,000 Roll #309426 SW-6-69-6-W6, Plan 03222694, Block 1, Lot 2 Opinion \$315,000 Roll #309587 SW-3-69-7-W6, Plan 0525878 Block 1, Lot 1 Opinion \$435,000 Roll #311066 SW-26-65-21-W5, Plan 9820795, Lot 1 Opinion \$60,000 Roll #311097 SE-14-69-8-W6, Plan 9825458, Lot 1 Opinion \$325,000 Roll #317447 SW-5-70-6-W6, Plan 1124095, Block 1, Lot 5 Opinion \$495,000 Roll #37908 NE-16-71-22-W5 Opinion \$120,000</p> <p>CARRIED</p>		
<p>June 24, 2019</p>	<p>MOTION: 19.06.512. Moved by: COUNCILLOR SHAWN ACTON That Council approve a capital grant in the amount of \$100,000.00 to the Grande Prairie Regional Hospital Foundation, Key to Care Capital Campaign, Bedside Engagement System, with funds to come from the Community Service Miscellaneous Grant.</p> <p>CARRIED</p>	<p>Com. Serv.</p>	<p>Complete</p>
<p>June 24, 2019</p>	<p>MOTION: 19.06.513. Moved by: COUNCILLOR DUANE DIDOW That Council award the Grande Cache Fitness Centre – Project Manager Contract to Colliers International in the amount of \$77,500.00, with funds to come from the 2019 Recreation Capital Budget.</p> <p>CARRIED</p>	<p>Com. Serv.</p>	

June 24, 2019	MOTION: 19.06.514. Moved by: COUNCILLOR ROXIE RUTT That Council provide a letter of support for the Valleyview Enhancement Society for the nomination for the A.V. Pettigrew Award through the Alberta Recreation and Parks Association. CARRIED	Com. Serv.	Complete
June 24, 2019	MOTION: 19.06.515. Moved by: COUNCILLOR DALE GERVAIS That Council appoint Sara Nichol to the Valleyview & District Recreation Board. CARRIED		Complete
19 06 10 RC Meeting			
June 10, 2019	MOTION: 19.06.436. Moved by: COUNCILLOR ROXIE RUTT That Council schedule a Public Hearing for Bylaw 19-823, Big Lakes County and Municipal District of Greenview No. 16 Intermunicipal Development Plan, to be held on June 24, 2019, at 10:00 a.m. CARRIED	Planning & Dev	Complete
June 10, 2019	MOTION: 19.06.437. Moved by: COUNCILLOR TYLER OLSEN That Council approve the purchase & installation of four (4) Rectangular-Rapid Flashing Beacons in the amount of \$34,131.69 coming from Road Infrastructure Reserves. CARRIED	Corp. Serv.	Complete
June 10, 2019	MOTION: 19.06.439. Moved by: COUNCILLOR DALE GERVAIS That Council award the Johnson Park expansion contract to A.B. Hollingworth & Son Construction in the amount of \$453,640.03, with funding to come from Recreation Capital Budget. CARRIED		
June 10, 2019	MOTION: 19.06.440. Moved by: COUNCILLOR DUANE DIDOW That Council approve the revised Joint Family and Community Support Services Agreement between the Municipal District of Greenview and the Town of Valleyview. Councillor Dale Gervais requested a recorded vote. For: Councillor Roxie Rutt, Reeve Dale Smith, Councillor Tyler Olsen, Councillor Duane Didow, Councillor Les Urness Opposed: Deputy Reeve Winston Delorme, Councillor Bill Smith, Councillor Dale Gervais, Councillor Shawn Acton CARRIED	Com. Serv.	In progress
June 10, 2019	MOTION: 19.06.441. Moved by: COUNCILLOR DUANE DIDOW That Council approve Policy 5001 Home Support as amended; • Policy 1 replace "on a cost sharing basis" with "based on a variable cost associated with the individual needs assessment". • Procedure 3.3 add "and clients" CARRIED		Complete

June 10, 2019	<p>MOTION: 19.06.442. Moved by: COUNCILLOR SHAWN ACTON That Council approve Policy 8004 Community Events and Charitable Donations as amended; • Policy 8 add "Policy 8002" CARRIED</p>		Complete
June 10, 2019	<p>MOTION: 19.06.443. Moved by: COUNCILLOR LES URNESS That Council for Approve Policy 8002 "Community Grants" as presented. CARRIED</p>		Complete
June 10, 2019	<p>MOTION: 19.06.444. Moved by: COUNCILLOR TYLER OLSEN That Council accept for information the 2019 Council Compensation Review. CARRIED</p>		Complete
June 10, 2019	<p>MOTION: 19.06.445. Moved by: COUNCILLOR BILL SMITH That Council directs Administration to seek a panel to do a Council Compensation review prior to October 2021. CARRIED</p>		
June 10, 2019	<p>MOTION: 19.06.446. Moved by: COUNCILLOR SHAWN ACTON That Council approve Policy 1031 Cyber Security as amended; • Procedure 6 add "and Council Members" CARRIED</p>		Complete
June 10, 2019	<p>MOTION: 19.06.449. Moved by: COUNCILLOR SHAWN ACTON That Council direct Administration to draft a resolution to RMA for the Fall Convention regarding the need to review and revise Utility Distribution Rates in rural and northern communities. CARRIED</p>		Complete
June 10, 2019	<p>MOTION: 19.06.450. Moved by: COUNCILLOR LES URNESS That Council approve Administration to Tender BF71667, funds to come from 2019 Capital Budget. CARRIED</p>	I & P	In Progress
June 10, 2019	<p>MOTION: 19.06.452. Moved by: COUNCILLOR DALE GERVAIS That Council direct Administration to replace BF71666 with Day Labour, with funds to come from the 2019 Capital Budget. CARRIED</p>	I & P	In Progress
June 10, 2019	<p>MOTION: 19.06.453. Moved by: DEPUTY REEVE WINSTON DELORME That Council direct Administration to replace BF78679 with Day Labour, funds to come from the 2019 Capital Budget. CARRIED</p>	I & P	In Progress

June 10, 2019	MOTION: 19.06.454. Moved by: Reeve Dale Smith That Council direct Administration to replace BF79561 with Day Labour funds to come from the 2019 Capital Budget. CARRIED	I & P	In Progress
June 10, 2019	MOTION: 19.06.455. Moved by: DEPUTY REEVE WINSTON DELORME That Council approve the naming of the Public Service Buildings to Grande Cache Public Service Building and Fire Station, DeBolt Public Service Building and Fire Station, and Grovedale Public Service Building and Fire Station, numbers to be determined by the date of inception. CARRIED	Com. Serv.	In progress
June 10, 2019	MOTION: 19.06.456. Moved by: COUNCILLOR BILL SMITH That Council authorize Administration to purchase new self-contained breathing apparatus cylinders, masks and hardware in the amount of \$25,000.00 for the Grovedale Fire Department, with funds to come from the Protective Services Budget. CARRIED	Com. Serv.	In progress
June 10, 2019	MOTION: 19.06.457. Moved by: COUNCILLOR BILL SMITH That Council authorize Administration to transfer \$25,000.00 from the Fire Apparatus Reserve to the Protective Services Budget. CARRIED	Corp. Serv.	Complete
June 10, 2019	MOTION: 19.06.458. Moved by: COUNCILLOR DALE GERVAIS That Council approve the \$275,000.00 2019 Nitehawk Ski Hill Budget to be allocated in the following portions \$100,000.00 operating grant and \$175,000.00 capital grant. CARRIED	Com. Serv.	Complete
June 10, 2019	MOTION: 19.06.459. Moved by: DEPUTY REEVE WINSTON DELORME That Council approve an additional \$92,000.00 capital grant to the Grande Prairie Ski Club operating as Nitehawk Year Round Adventure Park, with funds to come from Community Service Miscellaneous Budget. CARRIED	Com. Serv.	Complete
June 10, 2019	MOTION: 19.06.460. Moved by: COUNCILLOR ROXIE RUTT That Council approve a capital donation in the amount of \$10,000.00 to the Falher Friendship Corner Association for purchasing a property located in Falher, Alberta to develop a 24/7 developmental disability residence, with funds to come from Community Service Miscellaneous Grant. CARRIED	Com. Serv.	Complete
June 10, 2019	MOTION: 19.06.461. Moved by: COUNCILLOR DUANE DIDOW That Council approve the repurposing of the funds intended for the Grande Cache Seniors' Week to be utilized for the Grande Cache Big Horn Golden Age Club Welcome Back Dinner held September 2019 in Grande Cache, Alberta. CARRIED	Com. Serv.	Complete

June 10, 2019	MOTION: 19.06.464. Moved by: COUNCILLOR DUANE DIDOW That Council authorize Administration to enter into a five year agreement with the Philip J Currie Museum with an annual commitment of \$150,000.00, to come from the Community Services Budget. CARRIED	Com. Serv.	Complete
June 10, 2019	MOTION: 19.06.471. Moved by: COUNCILLOR BILL SMITH That Council direct Administration to proceed with the purchase of Lots 29&30, Block 6, Plan 052 5278. CARRIED	Planning & Dev	In Progress
19 05 27 RC Meeting			
May 27, 2019	MOTION: 19.05.404. Moved by: COUNCILLOR LES URNESS That Council defer Second Reading to Bylaw 19-815, for the Tri-Municipal Industrial Partnership Area Structure Plan until the June 24, 2019. CARRIED	Com. Serv.	Complete
May 27, 2019	MOTION: 19.05.406. Moved by: COUNCILLOR ROXIE RUTT That Council schedule a Public Hearing for Bylaw No. 19-822, to be held on June 24, 2019, at 10:00 a.m. for the re-designation of an 8.10 hectare (20.02-acre) ± area from Agricultural One (A-1) District to Agricultural Two (A-2) District within SW-28-69-07-W6. CARRIED	I&P	Complete
May 27, 2019	MOTION: 19.05.407. Moved by: DEPUTY REEVE WINSTON DELORME That Council approve Administration to proceed with the farmland access application to SE 17-67-22 W5 by extending Range Road 224 with funds to come from Block Funding. CARRIED	I&P	In Progress
May 27, 2019	MOTION: 19.05.414. Moved by: COUNCILLOR DALE GERVAIS That Council direct Administration to re-negotiate the Valleyview Cemetery Agreement. CARRIED	Com. Serv.	In progress
May 27, 2019	MOTION: 19.05.415. Moved by: COUNCILLOR SHAWN ACTON That Council authorize Administration to enter into a funding agreement with the Town of Valleyview for the operation of the Memorial Hall, located in Valleyview, Alberta. CARRIED	Com. Serv.	In progress
May 27, 2019	MOTION: 19.05.417. Moved by: COUNCILLOR DALE GERVAIS That Council direct Administration to arrange the Strategic Planning Session for September 5 & 6, 2019 in Grande Prairie, AB. CARRIED	CAO	In Progress
19 05 13 RC Meeting			

May 13, 2019	MOTION: 19.05.351. Moved by: COUNCILLOR LES URNESS That Council approve Administration to transfer \$45,000.00 from water reserves to a new capital budget job ID, WD19002, for Valleyview Rural Waterline Extension. CARRIED	Corp. Serv.	Complete
May 13, 2019	MOTION: 19.05.353. Moved by: COUNCILLOR DALE GERVAIS That Council approve Administration to transfer \$1 million from WW17001, Grovedale Collection System Project, to WD16004, Landry Heights Water Distribution System project. CARRIED	Corp. Serv.	Complete
May 13, 2019	MOTION: 19.05.356. Moved by: COUNCILLOR DALE GERVAIS That Council direct Administration to bring back a report on what a Community Policy Program would entail, including options. CARRIED	Com Serv	Complete
May 13, 2019	MOTION: 19.05.359. Moved by: COUNCILLOR BILL SMITH That Council direct Administration to acquire a lease at Shuttler Flats and to operate the site and work towards divestment of the site. CARRIED	Com. Serv.	In progress
May 13, 2019	MOTION: 19.05.361. Moved by: COUNCILLOR BILL SMITH That Council approve a grant in the amount of \$5,600.00 to Alberta Parks for the development of an emergency access boat launch to the Simonette River located within the Simonette Provincial Recreation Area, with funds to come from Protective Services Budget. CARRIED	Com. Serv.	In progress
May 13, 2019	MOTION: 19.05.364. Moved by: COUNCILLOR DUANE DIDOW That Council award Western Star and Freightliner Trucks of Grande Prairie, AB the 2019 Plow Truck (Hamlet of Grande Cache) Tender for the amount of \$294,829.30. Funds to come from the Equipment and Fleet Reserves. CARRIED	Corp. Serv.	Complete
May 13, 2019	MOTION: 19.05.366. Moved by: COUNCILLOR BILL SMITH That Council transfer \$671,187.00 from Grande Cache Unrestricted Net Assets to the Operating Contingency Reserve. CARRIED	Corp. Serv.	In progress
May 13, 2019	MOTION: 19.05.383. Moved by: COUNCILLOR BILL SMITH That Council hold the June 17, 2019 Grovedale Ratepayer BBQ at the Grovedale Community Hall and the July 15, 2019 Grande Cache Ratepayer BBQ at the Recreation Centre. CARRIED	CAO Serv.	
May 13, 2019	MOTION: 19.05.390. Moved by: COUNCILLOR DALE GERVAIS That Council direct Administration to proceed with intent to purchase or property for the Agriculture Services expansion. CARRIED	I&P/Ag	Complete

18 04 23 RC Meeting

April 23, 2019	<p>MOTION: 19.04.328. Moved by: COUNCILLOR ROXIE RUTT That Council host the 2019 Greenview Stakeholder Outreach Event at the Shot Shell Sporting Clay Range in Valleyview on Thursday, September 12, 2019. CARRIED</p>	I & P	In Progress
----------------	--	-------	-------------

19 04 08 RC Meeting

April 8, 2019	<p>MOTION: 19.04.290. Moved by: COUNCILLOR BILL SMITH That Council defer motion 19.04.287. Grovedale Public Service Building Site Dugout until more detailed information can be brought forward on options 2 and 3. CARRIED</p>	Community Service	In progress
April 8, 2019	<p>MOTION: 19.04.302. Moved by: COUNCILLOR DUANE DIDOW Council directs Administration bring back comparable information from similarly structured municipalities as Greenview on how the urban and rural residential tax rates are delineated. CARRIED</p>	Corp Serv	In Progress
April 8, 2019	<p>MOTION: 19.04.303. Moved by: COUNCILLOR DUANE DIDOW Council direct Administration provide a service level matrix of the municipal supplied services to all residents within the MD. CARRIED</p>	CAO Services / Corp Serv	In Progress
April 8, 2019	<p>MOTION: 19.04.304. Moved by: COUNCILLOR BILL SMITH That Council direct Administration to add the Grovedale South Wapiti Recreation Board to the Additional Named Insurer (ANI). CARRIED</p>	Corp. Serv.	In progress waiting on information from the Rec Board.
April 8, 2019	<p>MOTION: 19.04.309. Moved by: COUNCILLOR BILL SMITH That Council approve the MD of Greenview Library Board as an Additional Named Insurer (ANI). CARRIED</p>	Corp Services	In progress waiting on information from the Library Board

19 03 25 RC Meeting

March 25, 2019	<p>MOTION: 19.03.225. Moved by: COUNCILLOR TYLER OLSEN That Council direct Administration to conduct the Hamlet of Grande Cache Census in September 2019. CARRIED</p>	CAO Serv	To be conducted fall 2019
March 25, 2019	<p>MOTION: 19.03.226. Moved by: DEPUTY REEVE WINSTON DELORME That the Grande Cache Census questions include: the number of usual residents in the dwelling, as well as the age and gender of each resident, consistent with the census conducted by the M.D of Greenview in 2018. CARRIED</p>	CAO Serv	To be conducted fall 2019

March 25, 2019	MOTION: 19.03.228. Moved by: COUNCILLOR ROXIE RUTT That Council direct Administration to proceed with negotiation on land acquisition for the construction of TWP Road 701. CARRIED	I & P	In progress
March 25, 2019	MOTION: 19.03.253. Moved by: COUNCILLOR TYLER OLSEN That Council direct Administration to notify property owners located on Plan 772 2953, Block 29, Lots 27 & 25 and Plan 772 2953, Block 26, Lot 124 of their existing encroachment onto adjacent municipal properties, and proceed with necessary enforcement actions in accordance with the Land Use Bylaw. CARRIED	Planning & Dev	In progress
March 25, 2019	MOTION: 19.03.255. Moved by: COUNCILLOR BILL SMITH That Council approve three fulltime position for a Deputy Fire Chiefs for Grovedale, Grande Cache and DeBolt locations. CARRIED	Comm. Serv.	Ongoing
19 02 25 RC Meeting			
February 25, 2019	MOTION: 19.02.190. Moved by: COUNCILLOR DALE SMITH That Council agrees to apply the exemption from Section 631 of the Municipal Government Act, as per Ministerial Order MSL: 047/18, due to the boundary between Woodlands County and the M.D of Greenview No. 16 being comprised of Provincial Crown Land. CARRIED	CAO Services	Waiting for GOA Response
19 02 21 COW Meeting			
February 21, 2019	MOTION: 19.02.16. Moved by: REEVE DALE GERVAIS That Committee of the Whole recommend to Council to draft a letter to Minister Environment & Parks with regards of Greenview being a participating stakeholder with PLUZ. CARRIED	Comm. Serv	In progress, on hold due to election.
19 02 11 RC Meeting			
February 11, 2019	MOTION: 19.02.157. Moved by: DEPUTY REEVE WINSTON DELORME That Council direct Administration to proceed with the Recreation (REC) Lease application process to Alberta Environment and Parks (AEP) for the Jason Delorme Memorial site. CARRIED	Community Services / I & P	In progress
February 11, 2019	MOTION: 19.02.168. Moved by: DEPUTY REEVE WINSTON DELORME That Council grant approval to Administration to proceed with the installation of network connectivity infrastructure between Valleyview Administration Office and Grande Cache sites as listed on the attached. CARRIED	Corp Serv	Complete
19 01 28 RC Meeting			

January 28, 2019	MOTION: 19.01.116. Moved by: COUNCILLOR TYLER OLSEN That Council direct Administration to proceed to acquire ownership of the thirty-two (32) residential units currently held by Deloitte Restructuring, commonly known as Mainstreet Lofts in the Hamlet of Grande Cache. CARRIED	CAO	In Progress
January 28, 2019	MOTION: 19.01.130. Moved by: COUNCILLOR DALE SMITH That Council authorize Administration to proceed with the Solicitor General of Alberta application process to become an authorized employer of a Peace Officer Program within Greenview, with funds to come from the Protective Services Budget. CARRIED	Com. Serv.	In progress
January 28, 2019	MOTION: 19.01.140. Moved by: COUNCILLOR DALE SMITH That Council authorize Administration to enter into a Valleyview Library Agreement with the Town of Valleyview for the purpose of maintaining joint provision of library services. MOTION: 19.01.141. Moved by: COUNCILLOR TOM BURTON That Council defer motion 19.01.140. until a later Regular Council Meeting. CARRIED	Com. Serv.	In progress
19 01 21 COTW Meeting			
January 21, 2019	MOTION: 19.01.05. Moved by: COUNCILLOR ROXIE RUTT That Committee of the Whole recommend to Council to bring forward a delegation from the Safety Codes Council. CARRIED	I&P	In Progress
19 01 14 RC Meeting			
January 14, 2019	MOTION: 19.01.91. Moved by: COUNCILLOR DALE SMITH That Council approve the replacement of BF76768 on Twp. 670 in 2019 in the amount of \$795,000 with funds to come from Capital Infrastructure Reserve. CARRIED	I & P/Corp Serv	In Progress Corp. Serv. Has updated the dollar amount.
18 12 10 RC Meeting			
December 10, 2018	MOTION: 18.12.699. Moved by: COUNCILLOR BILL SMITH That Council agrees to apply the Intermunicipal Development Plan exemption from Section 631 of the Municipal Government Act, as per Ministerial Order MSL:047/18, as both the County of Grande Prairie and Greenview have a common boundary comprised of provincial crown land. CARRIED	CAO	Complete
December 10, 2018	MOTION: 18.12.719. Moved by: REEVE DALE GERVAIS That Council as a whole engage a third party to conduct the annual Council Self-Appraisal to occur in early 2019. CARRIED	Council	

18 11 26 RC Meeting

Nov. 26, 2018	<p>MOTION: 18.11.642. Moved by: COUNCILLOR LES URNESS That Council authorize the Reeve and Chief Administrative Officer to execute the proposed Community Development Initiative Agreement with the Town of Fox Creek and Town of Valleyview. CARRIED</p>	CAO Services	In Progress
Nov. 26, 2018	<p>MOTION: 18.11.676. Moved by: COUNCILLOR WINSTON DELORME That Council review and approve Revised Policy 1003, Vehicle Usage Policy.</p> <p>MOTION: 18.11.677. Moved by: COUNCILLOR SHAWN ACTON That Council defer motion 18.11., Policy 1003 Vehicle Usage Policy to the Policy Review Committee. CARRIED</p>	Corp Serv.	Complete

18 11 13 RC Meeting

18 10 22 RC Meeting

18 10 09 RC Meeting

Oct. 9, 2018	<p>MOTION: 18.10.559. Moved by: COUNCILLOR BILL SMITH That Council direct Administration to pursue the purchase of public land in the Grovedale area for industrial development, once Alberta Environment and Parks has reviewed their application to purchase process. CARRIED</p> <p>MOTION: 18.10.560. Moved by: REEVE DALE GERVAIS That Council rescind motion 18.10.559., in regard to the Grovedale Public Land Purchase. CARRIED</p> <p>MOTION: 18.10.561. Moved by: COUNCILLOR BILL SMITH That Council direct Administration to pursue the purchase of public land, NE 35-68-6 W6M and the NW 36-68-6 W6M, in the Grovedale area for industrial development. CARRIED</p>	I & P	In Progress- Application submitted to Public Lands through Bearsto. Anticipated completion date 2020+
--------------	--	-------	---

18 09 24 RC Meeting

September 24, 2018	<p>MOTION: 18.09.532. Moved by: COUNCILLOR WINSTON DELORME That Council authorize Administration to develop a plan for the purchase of land located at NW34 -70-19 W5M for the purpose of building a parking lot to accommodate parking for an adjacent boat launch located on Snipe Lake, subject to an approved development plan with Big Lakes County. CARRIED</p>	Comm. Serv.	Ongoing
--------------------	---	-------------	---------

September 24, 2018	MOTION: 18.09.533. Moved by: COUNCILLOR SHAWN ACTON That Council authorize Administration to develop a plan for a partnership with Big Lakes County to make improvements to a boat launch located on SW34-3-71-19 W5M. CARRIED	Comm. Serv.	Ongoing
September 24, 2018	MOTION: 18.09.536. Moved by: COUNCILLOR ROXIE RUTT That Council direct Administration to complete the Intermunicipal Collaboration Frameworks with Yellowhead County, Woodlands County, and Birch Hills County Administratively. CARRIED	CAO Serv	In Progress
September 24, 2018	MOTION: 18.09.537. Moved by: COUNCILLOR DALE SMITH That Council authorize the Reeve and CAO to complete the Intermunicipal Collaboration Framework with the County of Grande Prairie. CARRIED	CAO Serv	In progress
September 24, 2018	MOTION: 18.09.541. Moved by: COUNCILLOR WINSTON DELORME That Council direct Administration to complete the minor brushing and some ditch improvements to keep positive water drainage subject to authorization from the Town of Grande Cache if required and to complete a preliminary road and drainage elevation design in an effort to achieve standard road compliance. CARRIED	I & P	Complete
16 06 28 RC Meeting			
June 28, 2016	MOTION: 16.06.227. Moved by: COUNCILLOR GEORGE DELORME That Council direct administration to investigate the creation of a bylaw to support the Grande Cache Source Water Protection Plan around the air strip, Victor Lake and the Town of Grande Cache. CARRIED	CAO Serv	Waiting to hear back from TSI.